

# Stemin

**Breitbach**  
®

## EFLEX-RS



**Inhaltsverzeichnis**

**Table of Contents**

Beschreibung	Description	3 / 4 / 5 / 6	
Sicherheitsfaktor	Safety Factor	7	
Technische Eckdaten	Technical Details	8	
Ermittlung der Kupplungsgröße	Coupling Selection	9	
Abmessungen	<b>EFLEX-RSN</b> <b>EFLEX-RSA</b>	10	
	<b>EFLEX-RSN-T</b> <b>EFLEX-RSA-T</b>	11	
	<b>EFLEX-RSZ</b>	12	
	<b>EFLEX-RSH</b>	13	
	<b>RSH - Schaltgestänge</b> <b>RSH - Hand Lever Control</b>	14	
	<b>EFLEX-RSN-BS</b> <b>EFLEX-RSA-BS</b>	15	
	<b>EFLEX-RSN-BSZ</b> <b>EFLEX-RSA-BSZ</b>	16 17	
	<b>EFLEX-RSN-BT</b> <b>EFLEX-RSA-BT</b>	18	
	<b>EFLEX-RSN-V</b> <b>EFLEX-RSA-V</b>	19	
	<b>EFLEX-RSZ-V</b>	20	
	<b>EFLEX-RSN-ERB</b>	21	
	Zuordnungsliste für IEC-Normmotoren	Selection Table for IEC Standard Motors	22
	Nennleistungen	Nominal Power Ratings	23
Fragebogen zur Auslegung	Questionnaire for Selection	24	
Montageanleitung	Installation Instructions	25 / 26 / 27	

**Wichtige Mitteilung !**

In Maschinen werden Schwingungen und Anregungen erzeugt, die sich ggf. auf unseren Liefergegenstand auswirken. Da die dynamische Auslegung des gesamten Antriebsstranges, deren Teil unser Liefergegenstand ist, jedoch in Verantwortung des Maschinenherstellers liegt, empfehlen wir, den Antriebsstrang maschinendynamisch zu untersuchen und ggf. Schwingungsberechnungen und/oder – messungen durchzuführen. Auf Anfrage unterstützen wir Sie gerne gegen separaten Auftrag. Lediglich vorsorglich weisen wir darauf hin, dass wir für aus Schwingungen und Anregungen resultierende Schäden jeglicher Art keine Gewähr übernehmen, sofern die dynamischen Anforderungen an den Liefergegenstand vom Besteller nicht vorher spezifiziert wurden.

**Important Notice !**

In machines vibrations and/or shock loads could occur and could have an effect on the component(s) supplied by us. Because the dynamic design of the drive-train, of which our component(s) are part of, is the responsibility of the manufacturer, we recommend to you to check the drive-train and if necessary to perform a torsional vibration calculation and/or to perform vibration measurements. If requested we could support you based on a additional order. We would like to point out to you that in case the dynamic conditions have not been specified by the purchasing party we will not except any liability for damages as a result of vibrations and/or shock loads.

Das Recht auf Vervielfältigungen, Nachdruck und Übersetzung behalten wir uns vor. Maß- und Konstruktions-änderungen vorbehalten.

Druckschrift Nr. 211.00.D/E.02.05.09/07

All rights of duplication, reprinting and translation are reserved. We reserve the right to modify dimensions and constructions without prior notice.

Publication No. 211.00.D/E.02.05.09/07

### Allgemeines

Die EFLEX-RS ist eine elastische, robuste und durchschlagsichere Klauenkupplung und stellt ein ideales Übertragungselement für die Leistung zwischen Elektromotoren und z.B. Pumpen oder ähnliche Anlagen dar. Die Baureihe der EFLEX-RS umfasst 16 Baugrößen für Nenn Drehmomente von 40 bis 30.300 Nm.

### Dynamische Eigenschaften

Die EFLEX-RS ist eine Kupplung mit einer progressiven Kennlinie; die dynamische Drehsteifigkeit ( $C_{Tdyn}$ ) steigt bei zunehmender Belastung der Kupplung.

Bei Nullast ist die Drehfedersteife der EFLEX-RS relativ klein und es ergibt sich damit ein günstiges Verhältnis von Betriebsdrehzahl zur kritischen Drehzahl.

### Bauformen

**RSN** Bei der 2-teiligen Bauform muß für das Trennen von Wellen und Maschinen die Nabe um die Länge der Nocken verschoben werden.

**RSA** Bei der 3-teiligen Bauform ermöglicht das Lösen und zurückziehen des Teils 3 ein Trennen von Wellen und Maschinen ohne deren axiale Verschiebung.

### General

The EFLEX-RS is an elastic, robust and at the same time fail safe jaw coupling. The EFLEX-RS can be employed in applications like electric motor - centrifugal pump sets and other similar configurations. The 16 standard coupling sizes cover a nominal torque - range of 40 to 30.300 Nm.

### Dynamic Properties

The EFLEX-RS is a coupling with progressive characteristics, i.e. the dynamic torsional stiffness ( $C_{Tdyn}$ ) increases with increasing coupling load.

Under no-load conditions the torsional stiffness of the EFLEX-RS is relatively small which results in a favourable ratio between operating speed and critical speed.

### Types

**RSN**

This type consists of 2 parts - the two shaft-ends have to be displaced by the length of the jaws for separating the Drive-R and the Drive-N shaft.

**RSA**

This type consists of 3 parts - part 3 allows the separation of the Drive-R and Drive-N shaft without displacement of the shaft-ends.

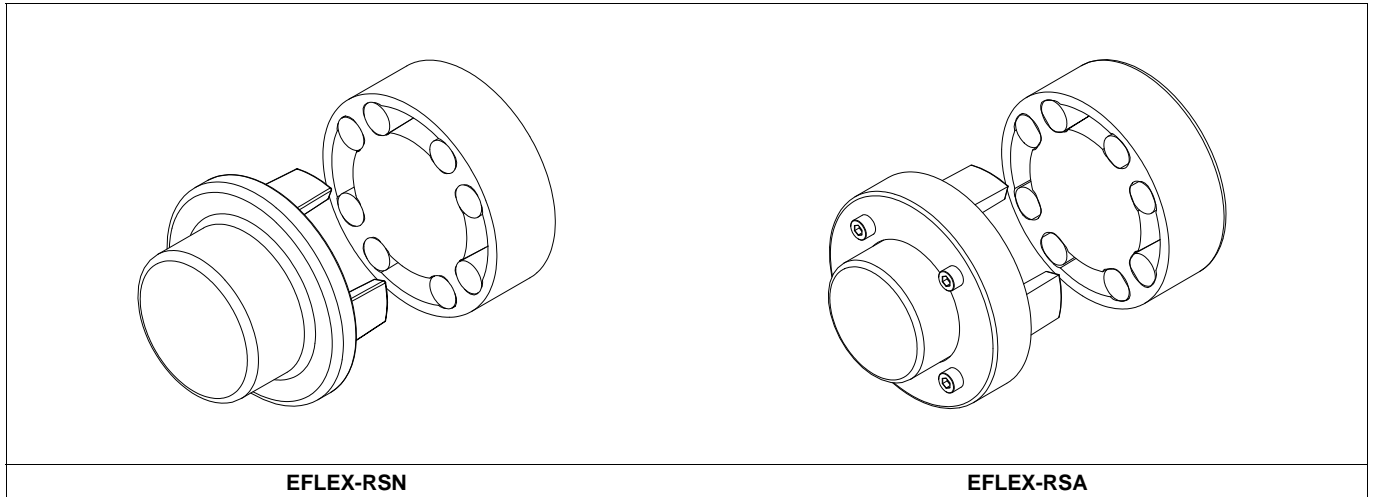

**EFLEX-RSN**

**EFLEX-RSA**

**RSN-T** Die EFLEX-RSN und EFLEX-RSA Kupplungen sind auf Anfrage auch lieferbar mit **Taperbush** Spannbuchsen, wodurch die Montage und Demontage einfach wird.

The EFLEX-RSN und EFLEX-RSA couplings are, on request, also available with bushes, type **Taperbush**, through which assembly and dismounting is very simple.

**RSN-T**

**RSA-T**

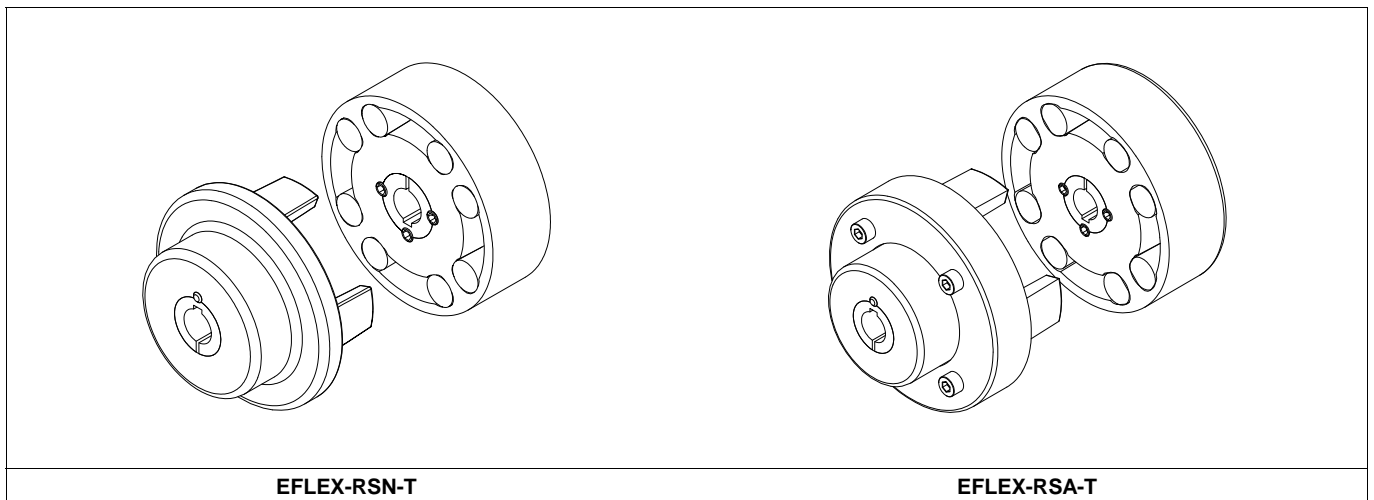

**EFLEX-RSN-T**

**EFLEX-RSA-T**

**RSZ** Bei dieser Bauform ermöglicht die Zwischenhülse z.B. in Kreiselpumpen-antrieben den Ausbau des Lagerstuhles mit Laufrad ohne Abbau des Motors.

This type with spacer allows for dismantling the Drive-N (e.g. centrifugal pump) without shaft displacement.

**RSZ**

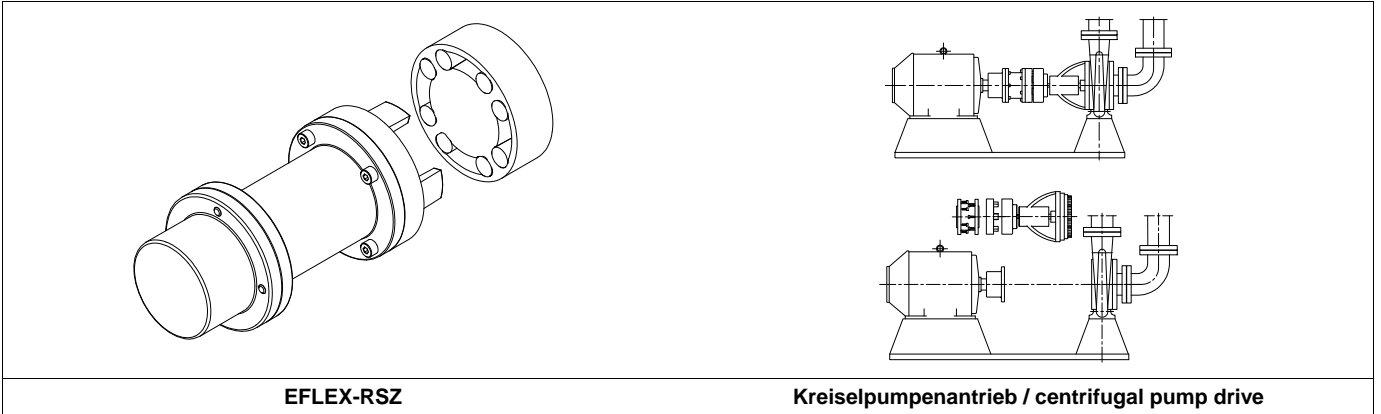

**EFLEX-RSZ**

**Kreiselpumpenantrieb / centrifugal pump drive**

**RSN-V**  
**RSA-V**  
**RSZ-V** 2-teilige, 3-teilige oder Zwischenhülsen Kupplung mit Flanschen.

2-part, 3-part or spacer coupling with flanges.

**RSN-V**  
**RSA-V**  
**RSZ-V**

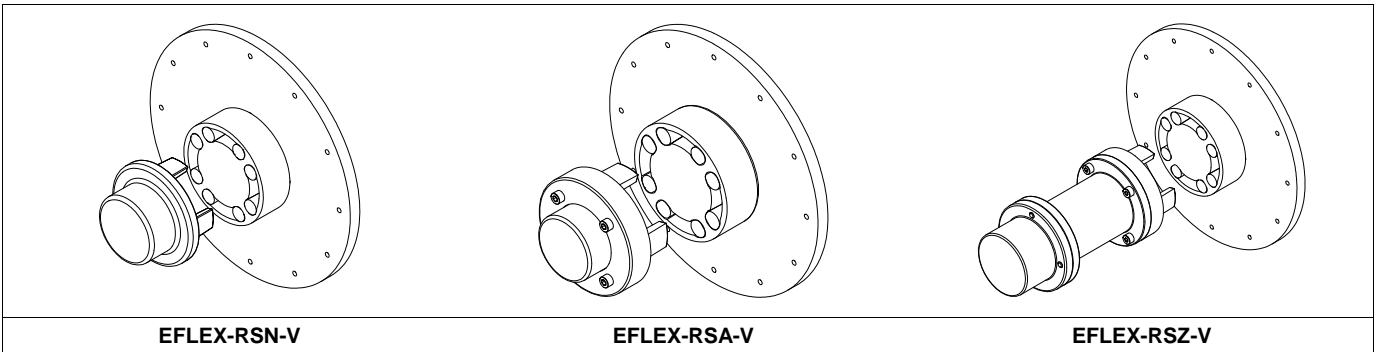

**EFLEX-RSN-V**

**EFLEX-RSA-V**

**EFLEX-RSZ-V**

**RSN-BS**  
**RSA-BS** 2-teilige oder 3-teilige Kupplung mit ange-schraubter Bremsscheibe nach DIN 15432.

2-part or 3-part coupling with bolted-on brakedisc in accordance to DIN 15432.

**RSN-BS**  
**RSA-BS**



**EFLEX-RSN-BS**

**EFLEX-RSA-BS**

**RSN-BSZ**  
**RSA-BSZ** 2-teilige oder 3-teilige Kupplung mit ange-schraubter radial ausbaubare Bremsscheibe nach DIN 15432.

2-part or 3-part coupling with bolted-on radial replaceable brakedisc in accordance to DIN 15432.

**RSN-BSZ**  
**RSA-BSZ**



**EFLEX-RSN-BSZ**

**EFLEX-RSA-BSZ**

**RSN-BT**  
**RSA-BT**

2-teilige oder 3-teilige Kupplung mit angeschraubter Bremstrommel für Sicherheitsbremsen nach DIN 15431.

2-part or 3-part coupling with bolted-on brake drum for safety-brakes in accordance to DIN 15431.

**RSN-BT**  
**RSA-BT**

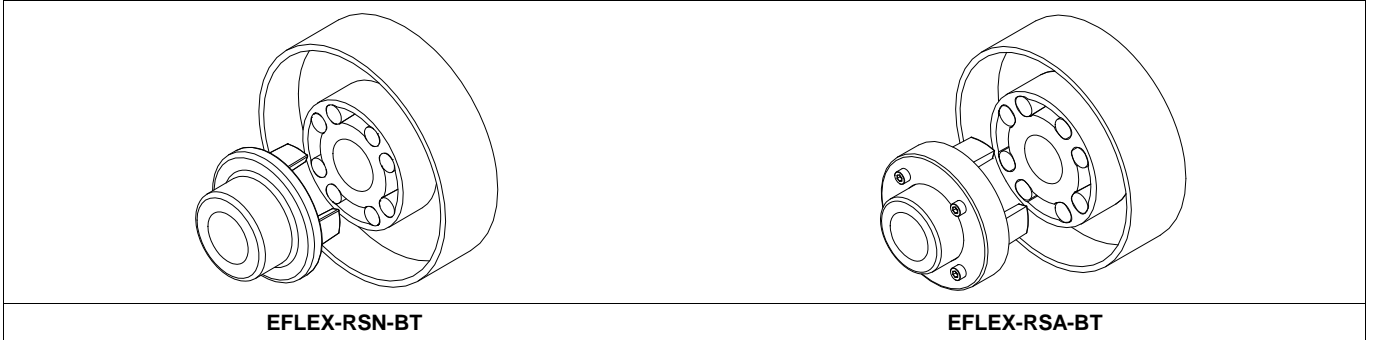

**EFLEX-RSN-BT**

**EFLEX-RSA-BT**

**RSH**

Kupplung im Stillstand schaltbar.

Mechanical operated jaw clutch.

**RSH**

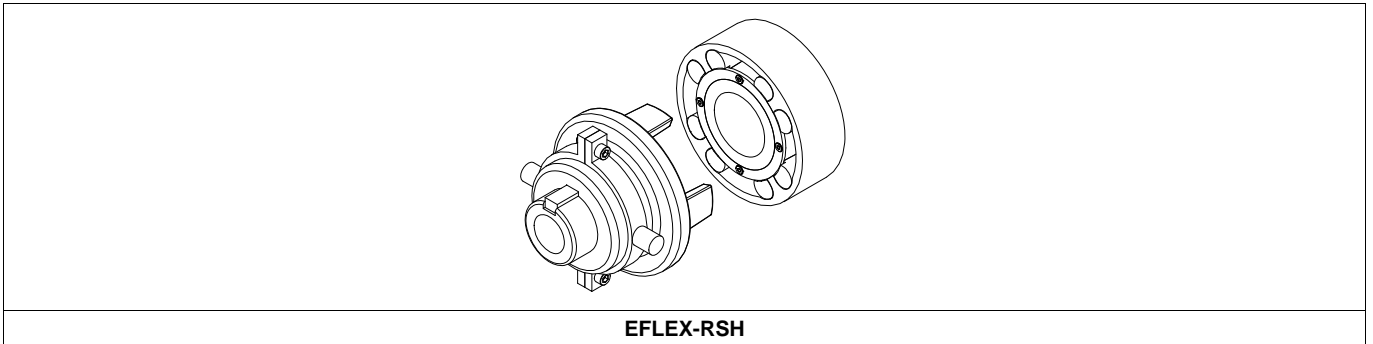

**EFLEX-RSH**

**RSN-ERB**

Drehelastische Sicherheitskupplung zur Verbindung von zwei Wellen.

Torsional soft torque limiter for connecting two shafts.

**RSN-ERB**

**RSN-A**

Ein in beiden Drehrichtungen einsetzbarer, für hohe Drehzahlen geeigneter Drehmoment-begrenzer mit automatischem Wieder-einrücken durch Drehrichtungsumkehr zum Anflanschen an einer elastischen EFLEX-RS Kupplung.

A bi-directional, highspeed operating torque limiter with automatic re-engagement by reversing direction of drive suitable to be mounted onto EFLEX-RS elastic couplings.

**RSN-A**

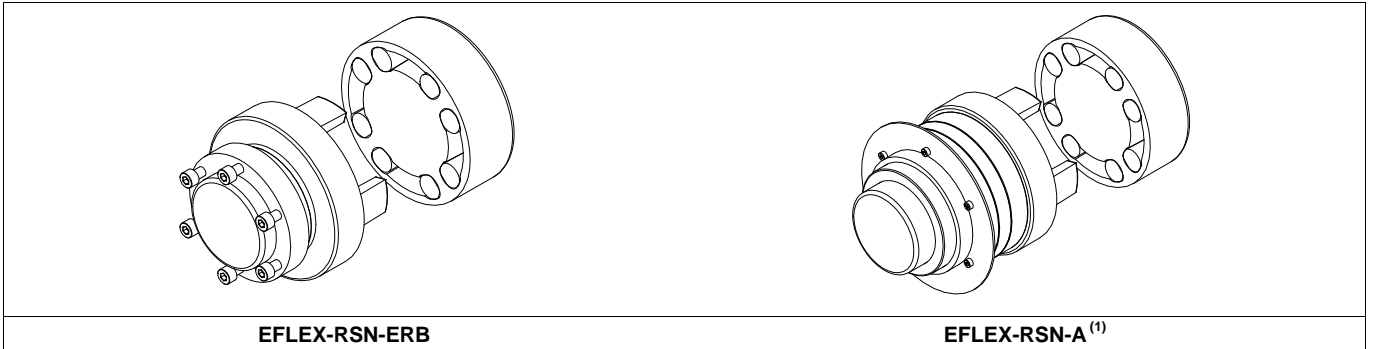

**EFLEX-RSN-ERB**

**EFLEX-RSN-A<sup>(1)</sup>**

(1) - auf Anfrage lieferbar / available on request

**Werkstoff der Metallteile**

Die Teile der EFLEX-RS werden aus hochwertigem Sphäroguß nach DIN-1693 hergestellt.

**Material for Metal Parts**

The metal parts for the EFLEX-RS coupling are manufactured out of spheroidal graphite cast-iron, according to DIN-1693.

**Werkstoff der elastischen Elemente**

Die elastische Elemente werden aus PUR (Polyurethan) angefertigt. PUR ist ölbeständig und abriebfest und wird in den Shorehärten 80 °Shore A (Temperaturbereich von -60 bis +70 °C) und 92 °Shore A (Temperaturbereich von -30 bis +80 °C) geliefert.

**Material for Elastic Elements**

The elastic material used is PUR (Polyurethane). PUR is oil- and abrasion-resistant and are supplied in the hardnesses 80 °Shore A (temperature range of -60 to +70 °C) and 92 °Shore A (temperature range of -30 to +80 °C).

**Ermittlung der Kupplungsgröße**

Bei der Auswahl der EFLEX-RS Kupplung hat man folgende zwei Alternativen :

**Selection of the Coupling**

If one is planning to select the right EFLEX-RS coupling there are two possible routes to follow:

1. Bestimmung der Kupplungsgröße unter Zugrundelegung des Motormomentes. Jedoch sollte ein Sicherheitsfaktor  $\geq 1,0$  verwendet werden. Die Ermittlung der Kupplungsgröße erfolgt nach der "DIN-740 - Blatt 2".
2. Die Auslegung der Kupplung kann auch durch uns erfolgen. Die für die Auslegung benötigte technische Daten tragen Sie bitte in Seite 24 ein und senden uns diese zu.

1. The coupling can be selected providing that the maximum torque of the engine is known. When making a selection one should multiply the maximum torque of the engine with a service factor of  $\geq 1,0$ . Whenever doing this we urge you to comply to the instructions as outlined in the DIN-740 - "Blatt - 2".
2. The selection can also be carried out by us. The for the selection necessary data can be sent to us after completing the form as per Page 24.

**Auswuchten**

Die Kupplungsteile der Bauform RSN/RSA  $\leq$  Größe 12 (Seite 10) werden in einer Ebene bei  $n_{max} = 1.500 \text{ min}^{-1}$ , nach Q-16 (VDI-2060 / ISO-1940), gewuchtet; ab Größe 13 auf Anfrage und nur mit Fertigbohrung (laut Tabelle).

**Für alle Größen** - Wuchten in zwei Ebenen wird empfohlen wenn es für die Laufruhe der Maschinenanlage erforderlich ist. Wuchten der Naben in zwei Ebenen ist nur möglich an Kupplungen mit Fertigbohrungen.

**Balancing**

The coupling parts type RSN/RSA  $\leq$  size 12 (page 10) are generally balanced in one plane at  $n_{max} = 1.500 \text{ min}^{-1}$  according to Q 16 (VDI-2060 / ISO-1940), from size 13 on request and only with finished bore (according to table).

**For all sizes** - when required the coupling parts can be balanced in two planes. Balancing of the hubs in two planes is only possible with finished bore.

Größe Size	Fertigbohrung finished bore
	d <sub>4</sub> min / d <sub>5</sub> min (mm)
13	50
14	50
15	50
16	60

Tabelle / Table

**Paßfedern und Bohrungen**

Das Bohrungstoleranzfeld laut ISO H7 für rundstirnige Paßfeder und Nut nach DIN 6885/1.

**Keyways and Bores**

Bore tolerance range according to ISO H7 and round headed parallel key and keyway according to DIN 6885/1.

**Massenträgheitsmoment und Masse**

Die Massenträgheitsmomente - J [kg.m<sup>2</sup>] - und Gewichte - M [kg] - gelten für mittlere Bohrungen.

**Mass Moment of Inertia and Mass**

The mass moments of inertia - J [kg.m<sup>2</sup>] - and masses - M [kg] - refer to couplings with medium-sized bores.

**Oberflächenbehandlung**

Die Kupplungsteile der EFLEX-RS werden in Normalausführung mangan-phosphatiert. Die Vorteile einer Manganphosphat-Schicht sind die gute Korrosions-beständigkeit und die ausgezeichnete Festigkeit gegen Abnutzung.

**Surface Protection**

Unless otherwise stated the metal parts of the EFLEX-RS coupling are treated with manganese phosphate. During this process a protective coating is created with the following properties: excellent corrosion protection and abrasion resistance.

Diese Art von Oberflächenbehandlung ist umweltfreundlich; die behandelten Oberflächen können - nach dem Entfetten - ohne weitere Behandlungen auch lackiert werden.

The other advantages of this process are: it is not harmful to the environment and a manganese phosphated product can be painted - after degreasing - without any additional preparation.

**Sicherheitsfaktor (S<sub>K</sub>)**

**Safety Factor (S<sub>K</sub>)**

	Elektromotor / Verbr. Motor ≥ 4 Zylinder  electric motor / comb. engine ≥ 4 cylinder	Verbr. Motor 2 - 3 Zylinder  comb. engine 2 - 3 cylinder	Verbr. Motor 1 Zylinder  comb. engine 1 cylinder
leichte Antriebe (z.B. Transportanlagen) light duty (e.g. conveyer belts)	1.0	1.3	1.7
mittlere Antriebe (z.B. industrielle Waschmaschinen) medium duty ( e.g. washing machines)	1.3	1.7	2.0
schwere Antriebe (z.B. Bagger) heavy duty (e.g. dredging engines)	1.7	2.0	2.3
sehr schwere Antriebe (z.B. Hammermühlen) extra heavy duty (e.g. hammer mills)	2.0	2.3	2.7

**Sicherheitsfaktor für täglichen Betriebsdauer (S<sub>b</sub>)**

**Safety Factor for Daily Operating time (S<sub>b</sub>)**

Stunden / hours	Faktor / factor
< 2	0,90
2 - 8	1,00
8 -16	1,15
> 16	1,25

**Anlauffaktor (S<sub>z</sub>)**

Faktor der die zusätzliche Belastung durch die Anfahrhäufigkeit Z (/Stunde) wie folgt berücksichtigt:

**Start-up Factor (S<sub>z</sub>)**

Factor which considers the additional loading caused by the start-up frequency Z (/hour) as follows:

Z ≤ 120	120 < Z ≤ 240	Z > 240
1,0	1,3	Rückfrage beim Hersteller Contact Manufacturer

**Temperaturfaktor (S<sub>θ</sub>)**

Faktor der das Absinken der Festigkeit von gummielastischen Werkstoffen bei Wärmeeinfluß berücksichtigt. Die Temperatur θ bezieht sich auf die unmittelbare Umgebung der Kupplung. Bei Einwirkung von Strahlungswärme ist dies besonders zu berücksichtigen.

**Temperature Factor (S<sub>θ</sub>)**

Factor which accounts for the reduction of the strength of the elastic materials under the effect of heat. The temperature θ refers to the immediate surroundings of the coupling. This is of particular importance in the case of radiation heat.

θ (°C)	S <sub>θ</sub> (PUR)
- 20 ≤ θ < + 30	1,0
+ 30 ≤ θ < + 40	1,1
+ 40 ≤ θ < + 60	1,2
+ 60 ≤ θ < + 80	1,3

**Drehzahlfaktor (S<sub>n</sub>)**

Faktor der den zulässigen radialen Wellenversatz bei erhöhter Drehzahl berücksichtigt.

**Rotational Speed Factor (S<sub>n</sub>)**

Factor which accounts for the permissible radial shaft displacement at increasing rotational speed.

Drehzahl / Speed (min <sup>-1</sup> )	S <sub>n</sub>
500	1,0
1.000	1,0
1.500	1,0
2.000	0,8
2.500	0,6
3.000	0,4

### TECHNISCHE ECKDATEN

#### zulässige Wellenversätze

Die aufgeführten Verlagerungswerte gelten bei Nenndrehmomente, stoßfreiem Betrieb, Drehzahl = 1.500 min<sup>-1</sup> und Umgebungstemperatur - 30°C bis + 80°C.

Zulässiger Versatz ist  $\Delta K_{r\_zul} \cdot S_n$  bzw.  $\Delta K_{w\_zul} \cdot S_n$  ( $S_n$  - Seite 7.).  $\Delta K_r$  und  $\Delta K_w$  können gleichzeitig auftreten. Die %-Summe der beiden vorhandenen Versätze  $\Delta K_{r\_vorh}$  und  $\Delta K_{w\_vorh}$  ist maximal 100%.

### TECHNICAL DETAILS

#### permissible shaft misalignment

The listed displacement values apply at nominal torque, under shock-free operating conditions, nominal speed = 1.500 min<sup>-1</sup> and ambient temperatures - 30°C to + 80°C.

Permissible displacement is  $\Delta K_{r\_zul} \cdot S_n$  or  $\Delta K_{w\_zul} \cdot S_n$  ( $S_n$  - Page 7.).  $\Delta K_r$  and  $\Delta K_w$  could occur simultaneously. The %-sum of the two measured displacements  $\Delta K_{r\_vorh}$  and  $\Delta K_{w\_vorh}$  should not exceed 100%.

$$\frac{\Delta K_{r\_vorh}}{\Delta K_{r\_zul}} \times 100\% + \frac{\Delta K_{w\_vorh}}{\Delta K_{w\_zul}} \times 100\% \leq 100\%$$

$\Delta K_{r\_zul} / \Delta K_{w\_zul} =$  zulässige Versätze / permissible displacements  
 $\Delta K_{r\_vorh} / \Delta K_{w\_vorh} =$  vorhandene Versätze / measured displacements

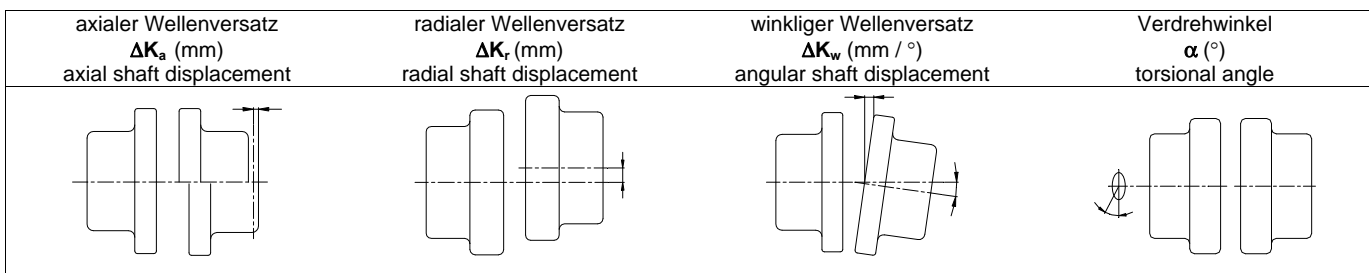

Größe / Size	1	2	3	4	5	6	7	8	9	10	11	12	13	14	15	16	
Nennmoment (92 °Shore A) nominal torque	$T_{kN}$ (Nm)	40	65	110	185	390	590	1.000	1.600	2.400	3.600	5.000	7.200	9.500	14.500	21.600	30.300
Nennmoment (80 °Shore A) nominal torque	$T_{kN}$ (Nm)	30	50	85	140	300	450	770	1.200	1.800	2.700	3.800	5.500	7.300	11.100	16.600	23.300
max. Drehzahl max. speed	$n$ (min <sup>-1</sup> )	10.000	8.700	7.500	6.300	5.700	5.000	4.400	3.900	3.300	2.900	2.700	2.300	2.100	1.900	1.600	1.350
Verdrehwinkel torsional angle	$\alpha$ (°)	3	3	3	3	3	3	3	3	3	3	3	3	3	3	3	3
axialer Wellenversatz axial shaft displacement	$\Delta K_a$ (mm)	±0,75	±0,75	±0,75	±1,00	±1,00	±1,25	±1,25	±1,25	±1,50	±1,50	±1,75	±2,00	±2,00	±2,50	±2,50	±2,50
radialer Wellenversatz parallel shaft displacement	$\Delta K_r$ (mm)	0,24	0,26	0,30	0,36	0,42	0,50	0,60	0,70	0,76	0,84	0,95	1,00	1,15	1,30	1,40	1,50
winkliger Wellenversatz angular shaft displacement	$\Delta K_w$ (mm)	±0,05	±0,06	±0,07	±0,08	±0,09	±0,11	±0,13	±0,15	±0,17	±0,20	±0,23	±0,25	±0,28	±0,31	±0,36	±0,41
winkliger Wellenversatz angular shaft displacement	$\Delta K_w$ (°)	0,10	0,10	0,10	0,10	0,10	0,10	0,10	0,10	0,10	0,10	0,10	0,10	0,10	0,10	0,10	0,10
Durchmesser Rollen diameter elements	$\varnothing$ (mm)	11,5	12,5	14,5	16,5	18,0	20,5	18,0	20,5	25,5	27,5	31,0	35,0	38,0	42,5	49,5	60,0
Anzahl der Rollen number of elements		6	8	8	8	8	8	12	12	12	12	12	12	12	12	12	12

## ERMITTLUNG DER KUPPLUNGSGRÖÖE

Die Ermittlung der Kupplungsgröße erfolgt nach der DIN-740 - Blatt 2

## COUPLING SELECTION

The selection is according to the instructions as outlined in the DIN-740 - Blatt 2

Eine EFLEX-RS Kupplung für den Antrieb eines Last-Aufzuges zwischen Elektromotor und Getriebe:

- Elektromotor  $P_m = 45 \text{ kW}$
- Wellen -  $\emptyset$   $d_r = 55 \text{ mm}$
- Getriebe  $P_2 = 38 \text{ kW}$
- Wellen -  $\emptyset$   $d_n = 50 \text{ mm}$
- Drehzahl  $n = 1.000 \text{ min}^{-1}$
- Tägliche Betriebsdauer 8 Stunden
- Anläufe je Stunde  $Z = 4$
- Umgebungstemperatur  $\vartheta = 35 \text{ }^\circ\text{C}$

An EFLEX-RS coupling for driving an elevator, to be mounted between electric motor and gearbox:

- Electric motor  $P_m = 45 \text{ kW}$
- Shaft -  $\emptyset$   $d_r = 55 \text{ mm}$
- Gearbox  $P_2 = 38 \text{ kW}$
- Shaft -  $\emptyset$   $d_n = 50 \text{ mm}$
- Speed  $n = 1.000 \text{ min}^{-1}$
- Daily operating time 8 hours
- Starts per hour  $Z = 4$
- Ambient temperatur  $\vartheta = 35 \text{ }^\circ\text{C}$

### Beispiel / Example

$$T(\text{Nm}) = S_k \times S_b \times S_z \times S_{\vartheta} \times \frac{9.550}{n(\text{min}^{-1})} \times P_2 (\text{kW}) \leq T_{kN} (\text{Nm})$$

$$=$$

$$T(\text{Nm}) = 1,3 \times 1,0 \times 1,0 \times 1,1 \times \frac{9.550}{1.000(\text{min}^{-1})} \times 38 (\text{kW}) = 519 \text{ Nm} \leq T_{kN} (\text{Nm})$$

Gewählte Kupplung

**EFLEX-RSN / RSA 6**

Selected Coupling

Bitte beachten, ob die maximale Bohrung geeignet ist für den Wellen -  $\emptyset$ . Wenn nicht, wählen Sie die nächst größere Kupplung.

Check that the maximum bore is suitable for the shaft -  $\emptyset$ . If not, select the next larger coupling size.

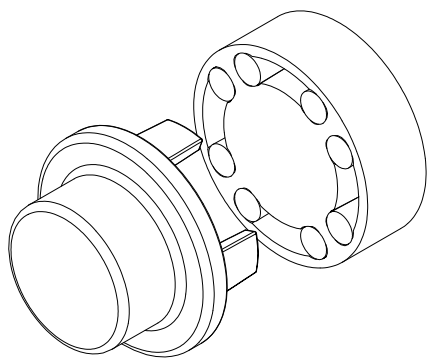

**EFLEX-RSN**

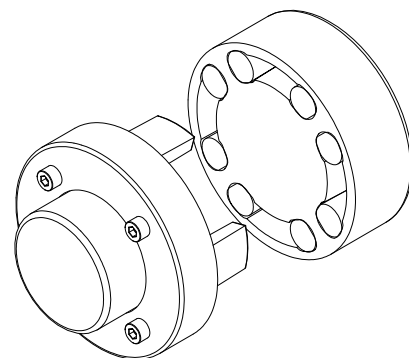

**EFLEX-RSA**

Bauform RSN & RSA

Type RSN & RSA

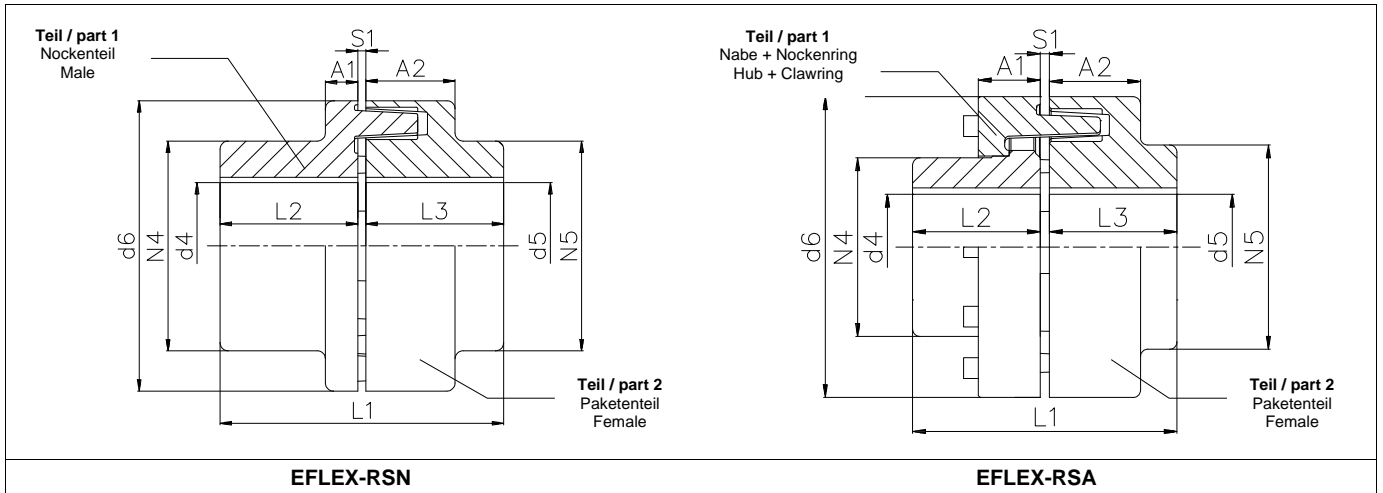

Größe Size	Nennmoment	max Drehzahl	min/max Bohrung	min/max Bohrung											Massenträgheitsmoment - J		Masse	
	T <sub>kN</sub>	n <sub>max.</sub>	d <sub>4</sub>	d <sub>5</sub>	L <sub>2</sub>	L <sub>3</sub>	d <sub>6</sub>	N <sub>4</sub>	N <sub>5</sub>	A <sub>1</sub>	A <sub>2</sub>	L <sub>1</sub>	S <sub>1</sub>	Teil 1 part 1	Teil 2 part 2	Teil 1 part 1	Teil 2 part 2	
	nominal torque	max speed	min/max bore	min/max bore	[mm]										mass moment of inertia - J		mass	
	[Nm]	[min <sup>-1</sup> ]											[kg.m <sup>2</sup> ]		[kg]			
N-01	40	10.000	0 - 30	0 - 30	25	25	65	45	65	8	25	53	3	0,0002	0,0002	0,3	0,4	
N-02	65	8.700	0 - 38	0 - 38	30	30	80	55	80	10	30	63	3	0,0004	0,0006	0,6	0,8	
N-03	110	7.500	0 - 42	0 - 42	35	35	94	60	94	10	35	73	3	0,0009	0,0014	1,0	1,1	
N-04	185	6.300	0 - 45	0 - 45	42	42	110	70	110	12	42	88	4	0,0020	0,0029	1,6	2,0	
A-04			0 - 45	62				22	0,0010	0,0029	1,8			2,0				
N-05	390	5.700	0 - 55	0 - 55	55	55	125	85	85	14	45	114	4	0,0043	0,0059	2,8	3,2	
A-05			0 - 50	70				26	0,0043	0,0059	2,8			3,2				
N-06	590	5.000	0 - 65	0 - 65	60	60	140	100	95	16	50	125	5	0,0081	0,0102	4,0	4,5	
A-06			0 - 55	79				30	0,0075	0,0102	3,9			4,5				
N-07	1.000	4.400	0 - 75	0 - 75	70	70	165	112	112	18	50	145	5	0,0159	0,0222	6,0	7,0	
A-07			0 - 75	98				34	0,0187	0,0222	6,3			7,0				
N-08	1.600	3.900	0 - 85	0 - 85	85	85	180	130	130	20	55	175	5	0,0297	0,0350	9,1	10,0	
A-08			0 - 75	110				37	0,0297	0,0350	8,9			10,0				
N-09	2.400	3.300	40 - 90	40 - 90	95	95	210	140	140	23	65	196	6	0,0544	0,0722	12,7	15,1	
A-09			0 - 90	130				41	0,0623	0,0722	13,5			15,1				
N-10	3.600	2.900	40 - 105	40 - 105	105	105	240	160	160	27	75	216	6	0,1061	0,1414	18,7	22,3	
A-10			40 - 105	153				45	0,1158	0,1414	20,0			22,3				
N-11	5.000	2.700	40 - 120	40 - 120	115	115	260	170	170	29	80	237	7	0,1579	0,2023	23,0	27,2	
A-11			40 - 120	168				49	0,1795	0,2023	25,5			27,2				
N-12	7.200	2.300	50 - 140	40 - 140	130	130	300	200	200	34	90	268	8	0,3341	0,4023	35,3	40,3	
A-12			40 - 140	198				53	0,3777	0,4023	39,0			40,3				
A-13	9.500	2.100	0 - 150	0 - 150	140	140	325	218	220	57	100	288	8	0,5599	0,6092	51,0	53,4	
A-14	14.500	1.900	0 - 160	0 - 160	170	170	360	228	230	61	110	350	10	0,8952	1,0045	69,0	74,6	
A-15	21.600	1.600	0 - 190	0 - 190	190	190	420	278	280	65	125	390	10	1,9300	2,1200	112,0	115,8	
A-16	30.300	1.350	0 - 225	0 - 225	210	210	515	338	340	80	145	430	10	5,1340	5,6315	188,5	198,7	

Werkstoff der elastischen Elemente - Polyurethan (PUR) / Shorehärtigkeit 92 °Shore A

Material Elastic Elements - Polyurethane (PUR) / Shorehardness - 92 °Shore A

Bauform RSN-T & RSA-T

Type RSN-T & RSA-T

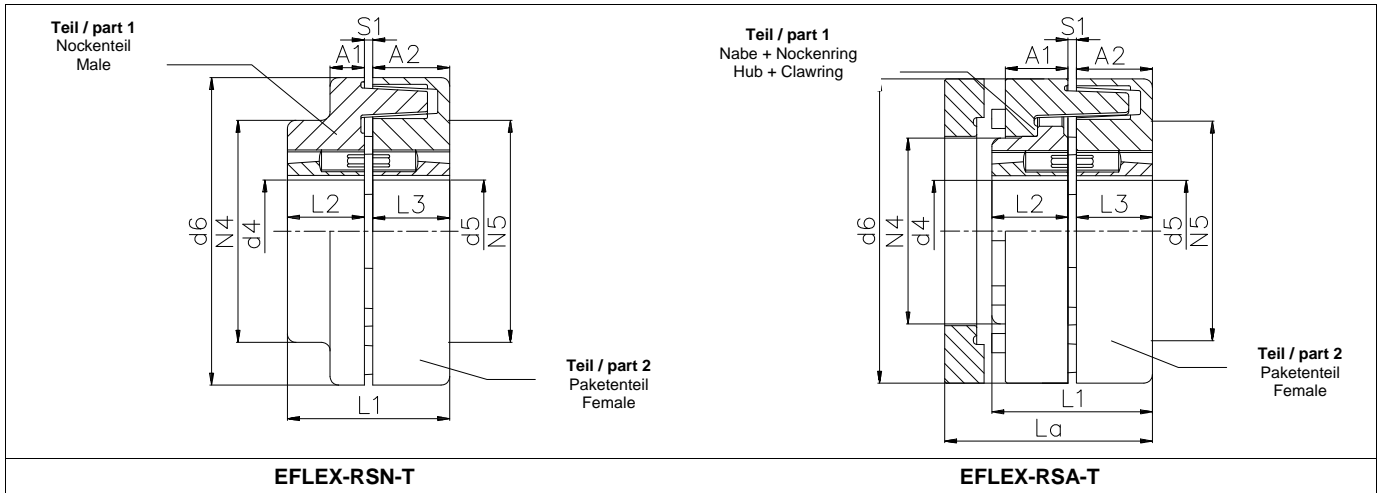

Größe Size	Nennmoment	max Drehzahl	Buchse Taperbush	max Bohrung											Massenträgheitsmoment - J		Masse	
	$T_{kN}^{(1)}$	$n_{max}$		$d_4/d_5$	$L_2$	$L_3$	$d_6$	$N_4$	$N_5$	$A_1$	$A_2$	$L_1$	$L_a$	$S_1$	Teil 1 part 1	Teil 2 part 2	Teil 1 part 1	Teil 2 part 2
	nominal torque	max speed	Bushing Taperbush	max bore	[mm]										mass moment of inertia - J		mass	
	[Nm]	[min <sup>-1</sup> ]													[kg.m <sup>2</sup> ]		[kg]	
N-T-02	65	8.700	1008	24	22	30	80	55	80	10	30	55	-	3	0,0039	0,0006	0,6	0,8
N-T-03	110	7.500	1108	28	22	35	94	60	94	10	35	60	-	3	0,0076	0,0014	0,8	1,2
N-T-04	147	6.300	1108	28	22	42	110	70	110	12	42	68	-	4	0,0017	0,0029	1,2	2,0
A-T-04					22	62	110	22	42	68	99	4	0,0023	0,0029	1,4	2,0		
N-T-05	390	5.700	1210	32	25	45	125	85	85	14	45	74	-	4	0,0032	0,0055	1,8	2,8
A-T-05					26	70	85	26	45	75	108	4	0,0042	0,0055	2,1	2,8		
N-T-06	486	5.000	1610	42	25	50	140	100	95	16	50	80	-	5	0,0057	0,0095	2,5	3,8
A-T-06					30	79	95	30	50	85	122	5	0,0077	0,0095	3,0	3,8		
N-T-07	808	4.400	2012	50	32	50	165	112	112	18	50	87	-	5	0,0117	0,0198	3,8	5,8
A-T-07					34	98	112	34	50	89	122	5	0,0164	0,0198	4,6	5,8		
N-T-08	1.311	3.900	2517	60	45	55	180	130	130	20	55	105	-	5	0,0218	0,0292	6,2	7,5
A-T-08					45	110	130	37	55	142	5	0,0257	0,0292	6,4	7,5			
N-T-09	1.311	3.300	2517	60	45	65	210	140	140	23	65	116	-	6	0,0410	0,0648	8,4	12,3
A-T-09					45	130	140	41	65	160	6	0,0530	0,0648	9,3	12,3			
N-T-10	2.712	2.900	3020	75	51	75	240	160	160	27	75	132	-	6	0,0817	0,1266	12,7	18,4
A-T-10					51	153	160	45	75	182	6	0,0958	0,1266	13,7	18,4			
N-T-11	2.712	2.700	3020	75	51	80	260	170	170	29	80	138	-	7	0,1433	0,1836	21,1	24,1
A-T-11					51	168	170	49	80	193	7	0,1697	0,1836	22,4	24,1			
N-T-12	7.200	2.300	4040	100	102	102	300	200	200	34	90	212	-	8	0,3029	0,3589	33,3	35,2
A-T-12					102	198	200	53	90	276	8	0,3487	0,3589	34,6	35,2			
A-T-13	9.500	2.100	4545	110	114	114	325	218	220	57	100	236	303	8	0,5177	0,5493	46,2	46,8
A-T-14	12.428	1.900	4545	110	114	114	360	228	230	61	110	238	314	10	0,7909	1,0592	56,6	68,6
A-T-15	14.236	1.600	5050	125	127	127	420	278	280	65	125	264	350	10	1,6189	1,8475	86,9	94,0
A-T-16	14.236	1.350	5050	125	127	145	515	338	340	80	145	282	368	10	4,3965	5,0408	147,0	165,8

Werkstoff der elastischen Elemente - Polyurethan (PUR) / Shorehärte 92 °Shore A Material Elastic Elements - Polyurethane (PUR) / Shorehardness - 92 °Shore A

Ohne Paßfeder (1) Without Key

Bauform RSZ

Type RSZ

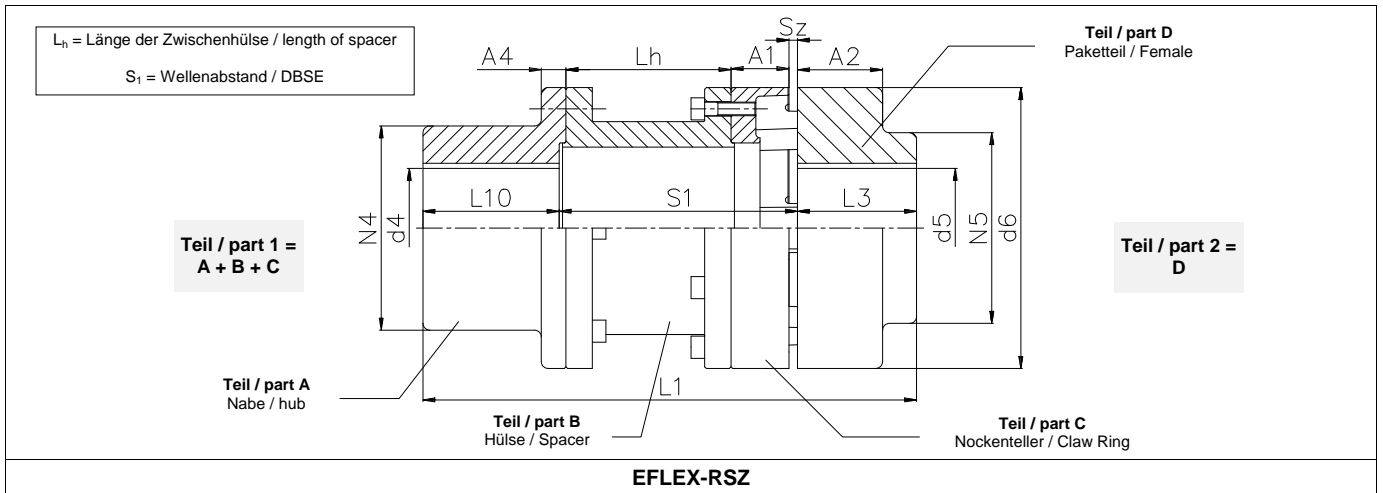

EFLEX-RSZ

Größe Size	Nennmoment $T_{KN}$	max. Drehzahl $n_{max}$	min/max Bohrung $d_4$	min/max Bohrung $d_5$	$d_6$	$N_4$	$N_5$	$L_1$	$L_{10}$	$L_3$	$S_1$	$A_2$	$A_4$	$L_h$	$A_1$	$S_z$	Massenträgheitsmoment - J		Masse	
	nominal torque [Nm]	max speed [min <sup>-1</sup> ]	min/max bore	min/max bore	[mm]											Teil 1 part 1	Teil 2 part 2	Teil 1 part 1	Teil 2 part 2	
																	mass moment of inertia - J		mass	
																	[kg.m <sup>2</sup> ]		[kg]	
Z-02	65	8.700	0 - 43	0 - 38	80	80	80	175 195 215	45	30	100 120 140	30	48	82 102 122	10	5	0,0024 0,0025 0,0025	0,0006	2,9 3,1 3,2	0,8
Z-03	110	7.500	0 - 60	0 - 42	94	94	94	185 205 225	50	35	100 120 140	35	53	82 102 122	10	5	0,0050 0,0052 0,0053	0,0014	4,1 4,3 4,5	1,1
Z-04	185	6.300	0 - 60	0 - 45	110	110	110	202 222 242	60	42	100 120 140	42	63	70 90 110	22	5	0,0110 0,0113 0,0116	0,0029	6,7 7,0 7,3	2,0
Z-05	390	5.700	0 - 60	0 - 55	125	90	85	220 240 260 280 300	65	55	100 120 140 160 180	45	11,5	66 86 106 126 146	26	5	0,0136 0,0142 0,0147 0,0153 0,0158	0,0059	7,2 7,6 8,0 8,4 8,8	3,2
Z-06	590	5.000	0 - 65	0 - 65	140	100	95	230 250 270 290 310 330 340	70	60	100 120 140 160 180 200 210	50	13	61 81 101 121 141 161 171	30	5	0,0220 0,0231 0,0242 0,0253 0,0263 0,0274 0,0279	0,0102	9,3 9,8 10,4 11,0 11,6 12,2 12,4	4,5
Z-07	1.000	4.400	0 - 80	0 - 75	165	120	112	270 290 310 330 350 360	80	70	120 140 160 180 200 210	50	14,5	77 97 117 137 157 167	34	5	0,0504 0,0526 0,0548 0,0570 0,0592 0,0603	0,0222	15,0 15,8 16,6 17,4 18,2 18,6	7,0
Z-08	1.600	3.900	0 - 90	0 - 85	180	135	130	295 315 335 355 375 425	90	85	120 140 160 180 200 250	55	19	73 93 113 133 153 203	37	6	0,0717 0,0742 0,0767 0,0793 0,0818 0,0881	0,0350	18,4 19,2 20,1 20,9 21,8 23,9	10,0
Z-09	2.400	3.300	0 - 100	40 - 90	210	150	140	335 355 375 395 445	100	95	140 160 180 200 250	65	19	88 108 128 148 198	41	7	0,1390 0,1450 0,1510 0,1580 0,1740	0,0722	24,5 25,8 27,1 28,3 31,5	15,1
Z-10	3.600	2.900	0 - 120	40 - 105	240	180	160	375 385 405 455	110	105	160 180 200 250	75	21	104 124 144 194	45	7	0,2950 0,3040 0,3140 0,3370	0,1410	38,6 40,1 41,5 45,1	22,3
Z-11	5.000	2.700	0 - 120	40 - 120	260	180	170	435 485	120	115	200 250	80	22,5	140 190	49	7	0,4140 0,4450	0,2020	48,4 52,7	27,2
Z-12	7.200	2.300	0 - 150	40 - 140	300	230	200	440 460 510	130	130	180 200 250	90	25	115 135 185	53	8	0,8820 0,9060 0,9680	0,4020	72,7 75,0 80,8	40,3
Z-13	9.500	2.100	0 - 150	0 - 150	325	230	220	480 530	140	140	200 250	100	25	131 181	57	8	1,1800 1,2600	0,6090	84,8 91,1	53,4
Z-14	14.500	1.900	0 - 180	0 - 160	360	270	230	520 570	150	170	200 250	110	28	125 175	61	10	1,9700 2,0700	1,0000	116,0 123,0	74,6
Z-15	21.600	1.600	0 - 210	0 - 190	420	320	280	600	160	190	250	125	30	171	65	10	4,2800	2,1200	184,0	116,0
Z-16	30.300	1.350	0 - 260	0 - 225	515	390	340	720	210	210	300	145	40	206	80	10	11,9000	5,6300	338,0	199,0

Werkstoff der elastischen Elemente - Polyurethan (PUR) / Shorehärte 92 °Shore A

Material Elastic Elements - Polyurethane (PUR) / Shorehardness - 92 °Shore A

## Bauform RSH

## Type RSH

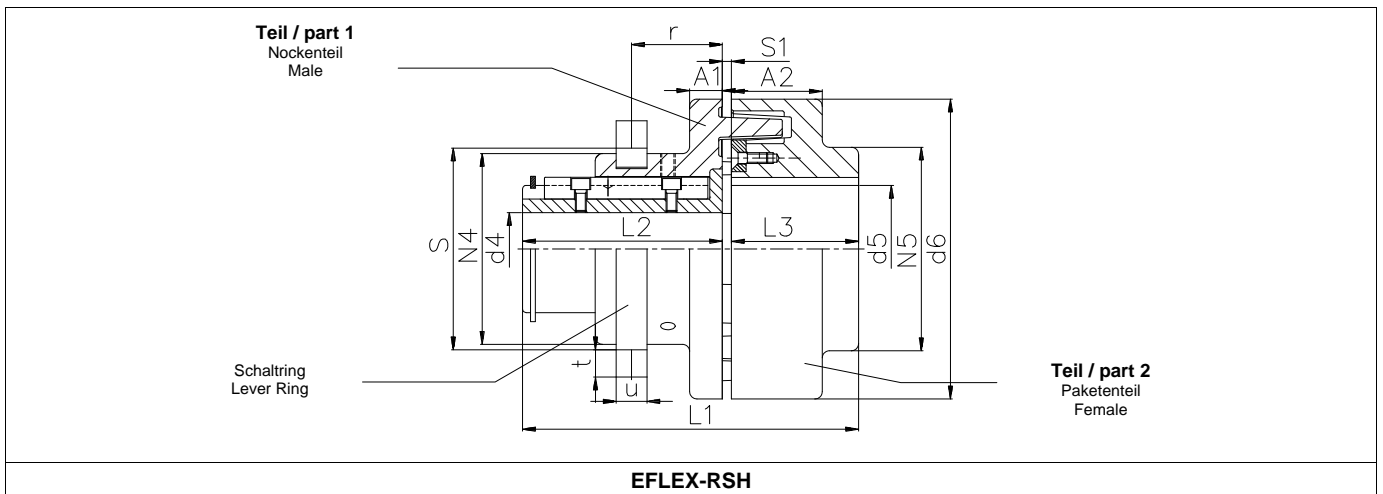

EFLEX-RSH

Größe Size	Nennmoment	max Drehzahl	min/max Bohrung		min/max Bohrung		Schaltkraft	Massenträgheitsmoment - J		Masse	
	$T_{KN}$	$n_{max}$	$d_4$		$d_5$			Teil 1 part 1	Teil 2 part 2	Teil 1 part 1	Teil 2 part 2
	nominal torque	max speed	min/max bore		min/max bore		operating force	mass moment of inertia - J		mass	
	[Nm]	[min <sup>-1</sup> ]	[mm]				[N]	[kg.m <sup>2</sup> ]		[kg]	
H-04	185	6.300	0	22	0	40	130	0,0025	0,0029	2,0	2,0
H-05	390	5.700	0	30	0	50	150	0,0053	0,0059	3,5	3,2
H-06	590	5.000	0	40	0	60	180	0,0105	0,0102	5,0	4,5
H-07	1.000	4.400	0	40	0	75	200	0,0223	0,0222	7,8	7,0
H-08	1.600	2.900	0	55	0	85	250	0,0401	0,0350	11,4	10,0
H-09	2.400	2.000	0	60	40	90	275	0,0815	0,0722	17,2	15,1
H-10	3.600	2.100	0	70	40	105	300	0,1523	0,1414	25,4	22,3
H-11	5.000	2.100	0	75	40	120	350	0,2393	0,2023	32,6	27,2
H-12	7.200	2.000	0	90	40	140	375	0,4606	0,4023	47,8	40,3
H-14	14.500	1.900	0	105	0	160	450	1,0916	1,0045	83,6	74,6
H-15	21.600	1.600	0	125	0	190	500	2,5076	2,1200	141,2	115,8
H-16	30.300	1.200	0	145	0	225	550	6,1626	5,6315	227,2	198,7

Größe Size	$d_6$	$N_4$	$N_5$	$S$	$L_1$	$L_2$	$L_3$	$A_1$	$A_2$	$S_1$	$r$	$t$	$u$
	[mm]												
H-04	110	70	110	85	126	80	42	12	42	4	30	15	10
H-05	125	85	85	90	154	95	55	14	45	4	35	10	12
H-06	140	100	95	111	170	105	60	16	50	5	40	15	17
H-07	165	112	112	111	185	110	70	18	50	5	50	15	17
H-08	180	130	130	140	220	130	85	20	55	5	55	17	17
H-09	210	140	140	170	251	150	95	23	65	6	60	18	17
H-10	240	160	160	185	281	170	105	27	75	6	70	25	20
H-11	260	170	170	185	302	180	115	29	80	7	75	25	20
H-12	300	200	200	220	343	205	130	34	90	8	85	30	20
H-14	360	230	230	250	440	260	170	40	110	10	110	30	25
H-15	420	280	280	300	500	300	190	47	125	10	120	30	28
H-16	515	340	340	360	540	320	210	55	145	10	135	30	35

Werkstoff der elastischen Elemente - Polyurethan (PUR) / Shorehärte 92 °Shore A

Material Elastic Elements Polyurethane (PUR) / Shorehardness 92 °Shore A

**Bauform RSH - Schaltgestänge**

**Type RSH - Hand Lever Control**

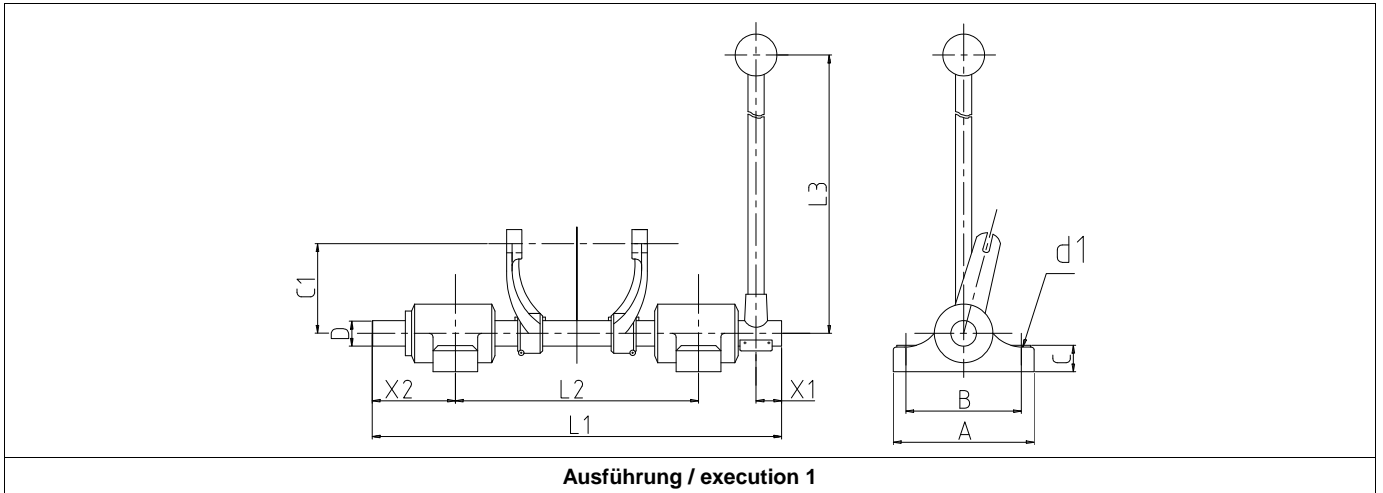

Ausführung / execution 1

**Ausführung 1**

**Execution 1**

Größe Size	A	B	C	D	L <sub>1</sub>	L <sub>2</sub>	L <sub>3</sub>	C <sub>1</sub>	d <sub>1</sub>	X <sub>1</sub>	X <sub>2</sub>
	[mm]										
5	110	75	18	20	320	190	400	70	11	20	65
6	140	100	25	25	430	270	450	97,5	14	20	80
7	140	100	25	30	490	310	600	120	14	20	90
8	140	100	25	30	490	310	600	120	14	25	90
15	160	120	25	40	630	410	1200	265	14	30	110
16	160	120	25	40	760	540	1200	265	14	30	110

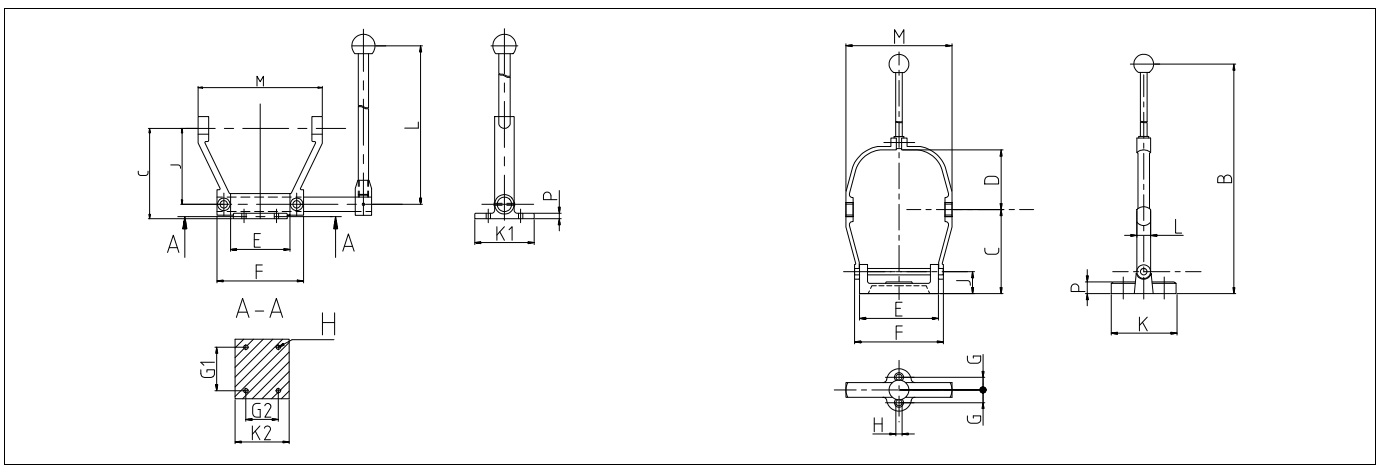

Ausführung / execution 2

Ausführung / execution 3

**Ausführung 2**

**Execution 2**

Größe Size	C	E	F	G <sub>1</sub>	G <sub>2</sub>	H	J	K <sub>1</sub>	K <sub>2</sub>	L	P	M
	[mm]											
12	205	170	230	85	100	13	170	110	150	550	12	265
14	215	170	230	85	100	13	180	110	150	1.000	12	295

**Ausführung 3**

**Execution 3**

Größe Size	B	C	D	E	F	G	H	J	K	L	P	M
	[mm]											
4	410	95	88	100	126	25	14	28	82	30	16	115
10	560	173	150	155	190	42,5	17	62	125	50	23	230

Bauform RSN-BS & RSA-BS (Metrisch)

Type RSN-BS & RSA-BS (Metric)

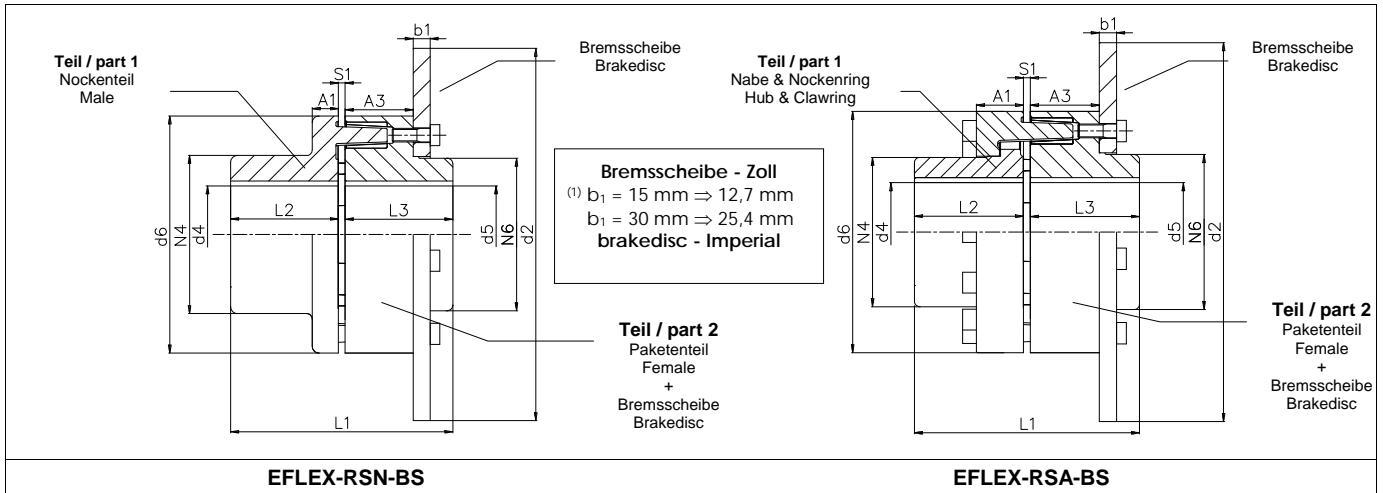

Größe Size	Nennmoment T <sub>KN</sub>		max Drehzahl n <sub>max</sub>		min/max Bohrung d <sub>4</sub> d <sub>5</sub>		[mm]										Massenträgheitsmoment - J Teil 1 part 1 Teil 2 part 2		Masse Teil 1 part 1 Teil 2 part 2	
	nominal torque [Nm]	max speed [min <sup>-1</sup> ]	min/max bore	min/max bore	d <sub>2</sub>	b <sub>1</sub> <sup>(1)</sup>	L <sub>2</sub>	L <sub>3</sub>	d <sub>6</sub>	N <sub>4</sub>	N <sub>6</sub>	A <sub>1</sub>	A <sub>3</sub>	L <sub>1</sub>	S <sub>1</sub>	mass moment of inertia - J [kg.m <sup>2</sup> ]	mass [kg]			
N-BS-04	185	3.500	0 - 45	0 - 45	250	15	42	42	110	70	70	12	40	01	4	0,0020	0,0438	1,6	6,8	
A-BS-04		2.800	0 - 40	0 - 45	250												315		315	62
N-BS-05	390	3.500	0 - 55	0 - 55	250	15	55	55	125	85	80	14	43	117	4	0,0043	0,0467	2,8	8,2	
A-BS-05		2.800	0 - 50	0 - 55	250												315		315	70
N-BS-06	590	2.800	0 - 65	0 - 65	315	15	60	60	140	100	90	16	47	127	5	0,0081	0,1140	4,0	12,5	
A-BS-06		2.500	0 - 55	0 - 65	315												355		315	79
N-BS-07	1.000	2.500	0 - 75	0 - 75	355	15	70	70	165	112	105	18	47	145	5	0,0159	0,1884	6,0	16,8	
A-BS-07		2.200	0 - 75	0 - 75	400												355		400	98
N-BS-08	1.600	2.200	0 - 85	0 - 85	400	15	85	85	180	130	125	20	52	175	5	0,0297	0,2990	9,1	21,0	
A-BS-08		2.000	0 - 75	0 - 85	450												400		450	110
N-BS-09	2.400	2.000	40 - 90	40 - 90	450	15	95	95	210	140	135	23	62	196	6	0,0544	0,4960	12,5	30,0	
A-BS-09		1.800	0 - 90	40 - 90	500												450		500	130
N-BS-10	3.600	1.800	40 - 105	40 - 105	500	30	105	105	240	160	155	27	72	216	6	0,1061	1,4414	18,7	59,2	
A-BS-10		1.600	40 - 105	40 - 105	560												500		560	153
N-BS-11	5.000	1.400	40 - 120	40 - 120	560	30	115	115	260	170	165	29	78	237	7	0,1579	2,2550	23,0	73,8	
A-BS-11		1.600	40 - 120	40 - 120	630												560		630	168
N-BS-12	7.200	1.400	50 - 140	40 - 140	630	30	130	130	300	200	195	34	88	268	8	0,3341	3,6747	35,3	98,1	
A-BS-12		1.200	40 - 140	40 - 140	710												630		710	198
A-BS-13	9.500	1.200	0 - 150	0 - 150	710	30	140	140	325	218	215	57	98	288	8	0,5599	5,8992	51,0	126,0	
A-BS-14	14.500	1.100	0 - 160	0 - 160	800	30	170	170	360	228	225	61	108	350	10	0,8952	9,1963	69,0	148,6	
A-BS-15	21.600	1.000	0 - 190	0 - 190	900	30	190	190	420	278	275	65	123	390	10	1,9300	15,6874	112,0	223,2	
A-BS-16	30.300	800	0 - 225	0 - 225	1.000	30	210	210	515	338	335	80	143	430	10	5,1331	22,9800	188,5	255,8	
		900			1.000												26,0836		324,1	
		700			1.120												38,2455		367,2	
					1.250												56,6497		419,5	

Werkstoff der elastischen Elemente - Polyurethan (PUR) / Shorehärte 92 °Shore A

Material Elastic Elements - Polyurethane (PUR) / Shorehardness - 92 °Shore A

Bauform RSN-BSZ & RSA-BSZ (Metrisch)

Type RSN-BSZ & RSA-BSZ (Metric)

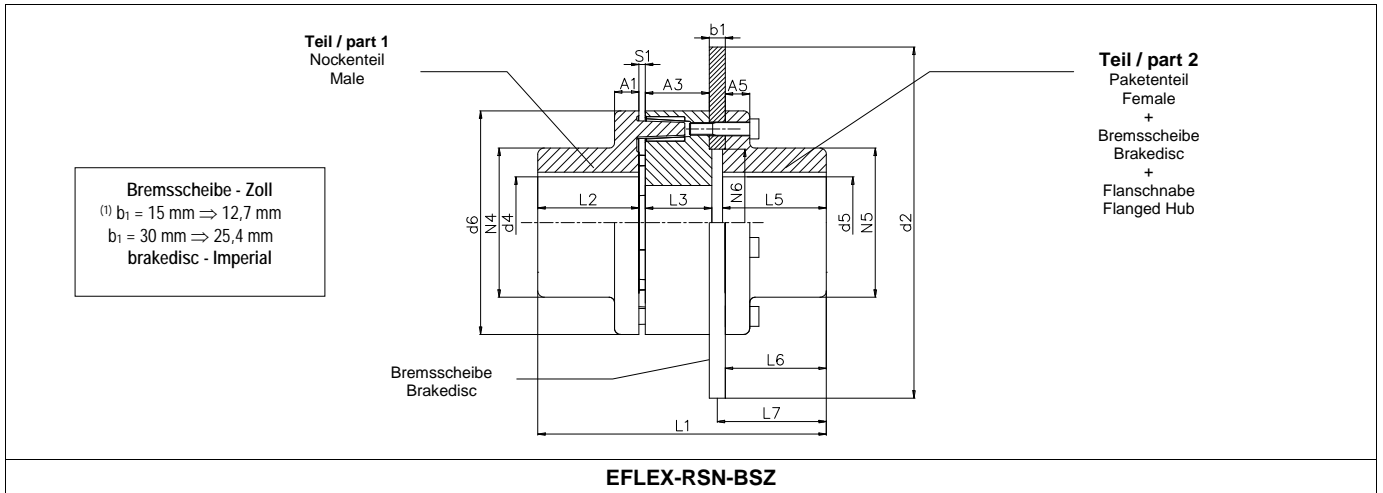

EFLEX-RSN-BSZ

Größe Size	Nennmoment $T_{KN}$ nominal torque [Nm]	max Drehzahl $n_{max}$ max speed [min <sup>-1</sup> ]	min/max Bohrung $d_4$ min/max bore	min/max Bohrung $d_5$ min/max bore	$d_2$	$b_1^{(1)}$	$L_2$	$L_3$	$L_5$	$L_6$	$L_7$	$d_6$
	[mm]											
N-BSZ-05	390	3.500	0 - 55	0 - 55	250	15	55	46	126	122,5	130	125
A-BSZ-05		2.800	0 - 50	250								
N-BSZ-06	590	2.800	0 - 65	0 - 65	315	15	60	50	126	122,5	130	140
A-BSZ-06		2.500	0 - 55	315								
N-BSZ-07	1.000	2.500	0 - 75	0 - 75	355	15	70	50	126	122,5	130	165
A-BSZ-07		2.200	0 - 75	355								
N-BSZ-08	1.600	2.200	0 - 85	0 - 85	400	15	85	55	126	122,5	130	180
A-BSZ-08		2.000	0 - 75	400								
N-BSZ-09	2.400	2.000	40 - 90	0 - 90	450	15	95	65	126	122,5	130	210
A-BSZ-09		1.800	0 - 90	450								
N-BSZ-10	3.600	1.800	40 - 105	0 - 105	500	30	105	75	158	155,0	170	240
A-BSZ-10		1.600	40 - 105	500								
N-BSZ-11	5.000	1.600	40 - 120	0 - 120	560	30	115	81	158	155,0	170	260
A-BSZ-11		1.400	40 - 120	560								
N-BSZ-12	7.200	1.400	40 - 140	0 - 140	630	30	130	91	158	155,0	170	300
A-BSZ-12		1.200	50 - 140	630								
A-BSZ-13	9.500	1.200	0 - 150	0 - 150	710	30	140	101	158	155,0	170	325
A-BSZ-14	14.500	1.100	0 - 160	0 - 160	800	30	170	111	183	180,0	195	360
A-BSZ-15	21.600	1.000	0 - 190	0 - 190	900	30	190	126	183	180,0	195	420
A-BSZ-16	30.300	900	0 - 225	0 - 225	1.000	30	210	146	183	180,0	195	515

Werkstoff der elastischen Elemente - Polyurethan (PUR) / Shorehärte 92 °Shore A

Material Elastic Elements - Polyurethane (PUR) / Shorehardness - 92 °Shore A

Bauform RSN-BSZ & RSA-BSZ (Metrisch)

Type RSN-BSZ & RSA-BSZ (Metric)

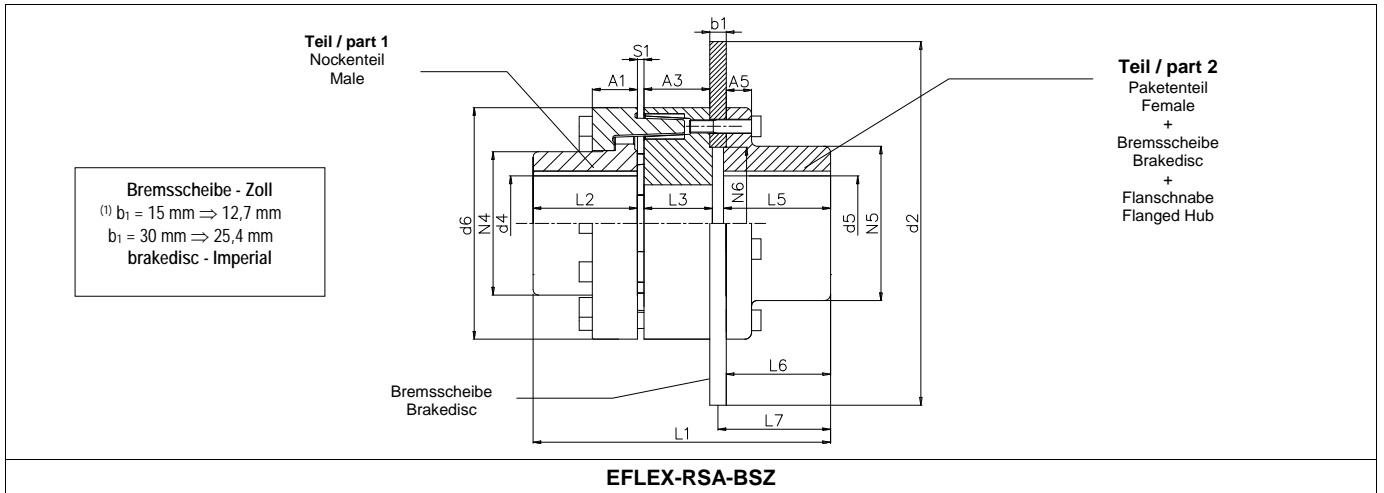

Größe Size	[mm]								Massenträgheitsmoment - J		Masse	
	N <sub>4</sub>	N <sub>5</sub>	N <sub>6</sub>	A <sub>1</sub>	A <sub>3</sub>	A <sub>5</sub>	L <sub>1</sub>	S <sub>1</sub>	Teil 1 part 1	Teil 2 part 2	Teil 1 part 1	Teil 2 part 2
	[mm]								mass moment of inertia - J		mass	
	[mm]								[kg.m <sup>2</sup> ]		[kg]	
N-BSZ-05	85			14					0,043	0,0526	2,8	11,4
A-BSZ-05	70	85	70	26	43	14	240	4	0,043	0,1156	2,8	14,5
N-BSZ-06	100			16					0,0081	0,1242	4,0	17,0
A-BSZ-06	79	95	90	30	47	16	250	5	0,0075	0,1882	3,9	19,2
N-BSZ-07	112			18					0,0159	0,2106	6,0	23,8
A-BSZ-07	98	112	105	34	47	18	260	5	0,0187	0,3137	6,3	26,8
N-BSZ-08	130			20					0,0297	0,3340	9,1	31,0
A-BSZ-08	110	130	125	37	52	20	280	5	0,0297	0,4973	8,9	34,5
N-BSZ-09	140			23					0,0544	0,5682	12,5	45,1
A-BSZ-09	130	140	135	41	62	23	301	6	0,0623	0,7961	13,5	48,3
N-BSZ-10	160			27					0,1064	1,5828	18,7	81,5
A-BSZ-10	153	160	155	45	2	27	368	6	0,1158	2,3429	20,0	92,2
N-BSZ-11	170			29					0,1579	2,4573	23,0	101,0
A-BSZ-11	168	170	165	49	78	29	385	7	0,1795	3,7123	25,5	115,2
N-BSZ-12	200			34					0,3341	4,0770	35,3	138,4
A-BSZ-12	198	200	195	53	88	34	411	8	0,3777	6,1252	39,0	156,3
A-BSZ-13	218	220	215	57	98	36	431	8	0,5599	6,5084	51,0	179,4
A-BSZ-14	228	230	225	61	108	40	498	0	0,8952	9,8055	69,0	266,6
A-BSZ-15	278	280	275	65	123	47	533	10	1,9300	10,5279	112,0	339,0
A-BSZ-16	338	340	335	80	143	55	573	10	5,1340	15,7551	188,5	522,8
										17,8074		371,6
										25,1000		371,6
										31,7151		522,8
										43,8770		565,9
										62,2812		618,2

Werkstoff der elastischen Elemente - Polyurethan (PUR) / Shorehärte 92 °Shore A

Material Elastic Elements - Polyurethane (PUR) / Shorehardness - 92 °Shore A

Bauform RSN-BT & RSA-BT

Type RSN-BT & RSA-BT

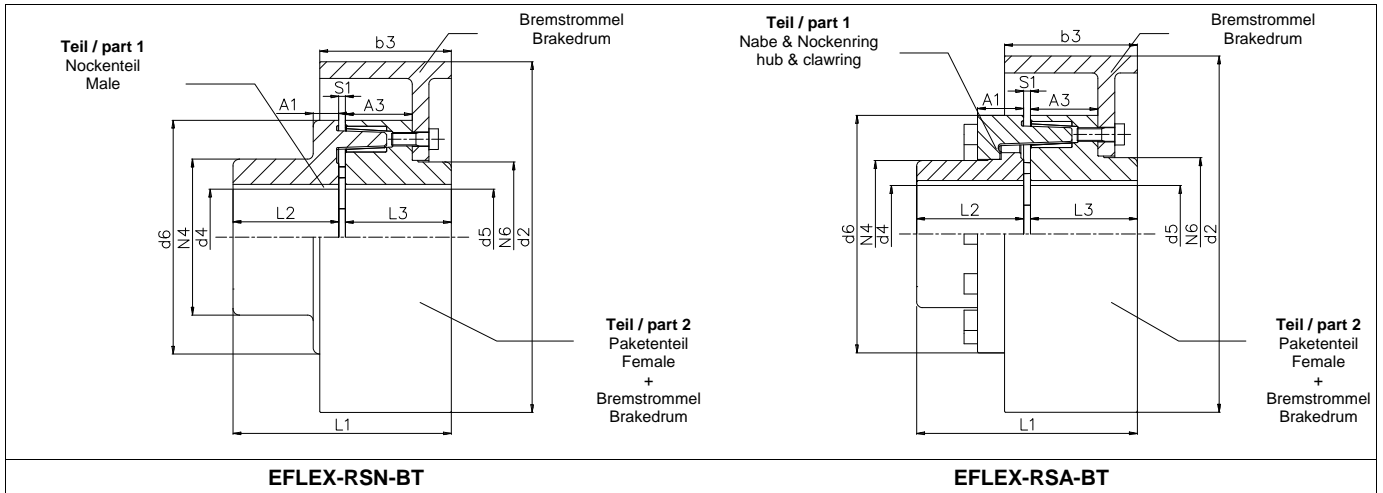

Größe Size	Nennmoment $T_{KN}$	max Drehzahl $n_{max}$	min/max Bohrung $d_4$	min/max Bohrung $d_5$	$d_2$	$b_3$	$L_2$	$L_3$	$d_6$	$N_4$	$N_6$	$A_1$	$A_3$	$L_1$	$S_1$	Massenträgheitsmoment - J		Masse	
	nominal torque [Nm]	max speed [min <sup>-1</sup> ]	min/max bore	min/max bore												Teil 1 part 1	Teil 2 part 2	Teil 1 part 1	Teil 2 part 2
	[mm]															mass moment of inertia - J [kg.m <sup>2</sup> ]		mass [kg]	
N-BT-04	185	3.400	0 - 45	0 - 45	200	75	42	42	110	70	70	12	40	102	4	0,0020	0,0481	1,6	8,2
A-BT-04		3.400	0 - 45	0 - 45	200	75				62	70	22				0,0010	0,0481	1,8	8,2
N-BT-05		3.400	0 - 55	0 - 55	200	75				85		14		118		0,0043	0,0511	2,8	9,4
A-BT-05	390	2.750			250	95								120	4		0,1406		15,2
		3.400	0 - 50	0 - 50	200	75	55	55	125		80		44	118		0,0043	0,0511	2,8	9,4
		2.750			250	95				70		26		120			0,1406		15,2
N-BT-06		3.400	0 - 65	0 - 65	200	75				100		16		128		0,0081	0,0554	4,0	10,6
A-BT-06	590	2.750			250	95								130			0,1445		16,4
		3.400	0 - 55	0 - 55	200	75	60	60	140		90		47	128	5	0,0075	0,0554	3,9	10,6
		2.750			250	95				79	90	30		130			0,1445		16,4
N-BT-07		2.750	0 - 75	0 - 75	250	95				112		18				0,0159	0,1548	6,0	18,5
A-BT-07	1.000	2.150			315	118								47	145	5	0,3897	0,1548	27,4
		2.750	0 - 75	0 - 75	250	95	70	70	165		105		34			0,0187	0,3897	6,3	18,5
		2.150			315	118				98							0,1548		27,4
N-BT-08		2.750	0 - 85	0 - 85	250	95				130		20				0,0297	0,1625	9,1	20,6
A-BT-08	1.600	2.150			315	118								52	175	5	0,3922	0,1625	28,2
		2.750	0 - 75	0 - 75	250	95	85	85	180		125		37			0,0297	0,3922	8,9	20,6
		2.150			315	118				110							0,1625		28,2
N-BT-09		2.150	40 - 90	40 - 90	315	118				140		23				0,0544	0,4241	12,5	33,2
A-BT-09	2.400	1.700			400	150								62	196	6	1,0579	0,4241	47,1
		2.150	0 - 90	0 - 90	315	118	95	95	210		135		41			0,0623	1,0579	13,5	33,2
		1.700			400	150				140							0,4241		47,1
N-BT-10		2.150	40 - 105	40 - 105	315	118				160		27				0,1061	0,4861	18,7	39,4
A-BT-10	3.600	1.700			400	150								72	216	6	1,1224	0,4861	53,3
		2.150	40 - 105	40 - 105	315	118	105	105	240		155		45			0,1158	1,1224	20,0	39,4
		1.700			400	150				153							0,4861		53,3
N-BT-11		1.700	40 - 120	40 - 120	400	150				170		29				0,1579	1,1758	23,0	58,0
A-BT-11	5.000	1.400			500	190								78	237	7	3,2206	1,1758	87,5
		1.700	40 - 120	40 - 120	400	150	115	115	260		165		49			0,1795	3,2206	25,5	58,0
		1.400			500	190				168							1,1758		87,5
N-BT-12		1.700	40 - 140	40 - 140	400	150				200		34				0,3341	1,3436	35,3	68,5
A-BT-12	7.200	1.400			500	190								88	268	8	3,4027	1,3436	98,2
		1.700	50 - 140	50 - 140	400	150	130	130	300		195		53			0,3777	3,4027	39,0	68,5
		1.400			500	190				198							1,3436		98,2
A-BT-13	9.500	1.400	0 - 150	0 - 150	500	190								98	288	8	3,5549	1,3436	108,0
		1.100			630	236	140	140	325		215		57			0,5599	8,9074	51,0	158,2
A-BT-14	14.500	1.400	0 - 160	0 - 160	500	190								108	350	10	3,8942	1,3436	123,4
		1.100			630	236	170	170	360		225		61			0,8952	9,1861	69,0	173,3
A-BT-15	21.600	1.100	0 - 190	0 - 190	630	236								123	390	10	10,0913	1,3436	205,2
		950			710	265	190	190	420		275		65			1,9300	15,4212	112,0	238,7
A-BT-16	30.300	950	0 - 225	0 - 225	710	265								143	430	10	18,5464	1,3436	306,2
		850			800	300	210	210	515		335		80			5,1340	27,4721	188,5	349,3

Werkstoff der elastischen Elemente - Polyurethan (PUR) / Shorehärte 92 °Shore A

Material Elastic Elements - Polyurethane (PUR) / Shorehardness - 92 °Shore A

Bauform RSN-V & RSA-V

Type RSN-V & RSA-V

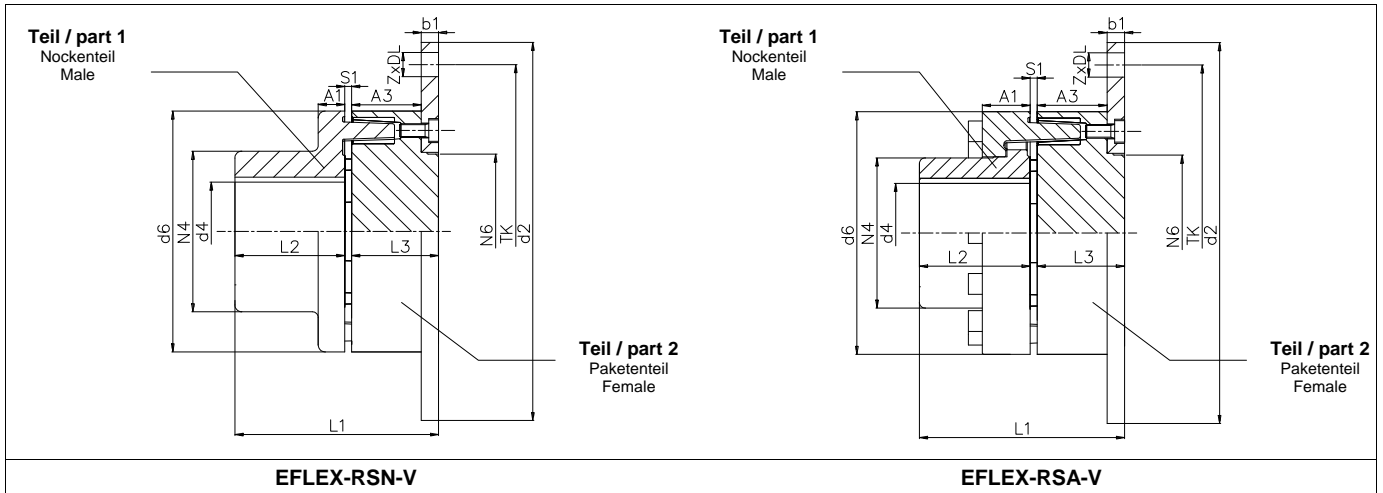

Größe Size	Flansch	Nennmoment	max Drehzahl	min/max Bohrung											Massenträgheitsmoment - J		Masse	
	d <sub>2</sub> (h8)	T <sub>kN</sub>	n <sub>max.</sub>	d <sub>4</sub>	b <sub>1</sub>	L <sub>2</sub>	L <sub>3</sub>	d <sub>6</sub>	N <sub>4</sub>	N <sub>6</sub>	A <sub>1</sub>	A <sub>3</sub>	L <sub>1</sub>	S <sub>1</sub>	Teil 1 part 1	Teil 2 part 2	Teil 1 part 1	Teil 2 part 2
	flange	nominal torque	max speed	min/max bore	[mm]										mass moment of inertia - J		mass	
	[mm]	[Nm]	[min <sup>-1</sup> ]		[mm]										[kg.m <sup>2</sup> ]		[kg]	
N-V-05 A-V-05	158	390	4.850	0 - 55 0 - 50	14	55	57	125	85 70	80	14 26	43	116	4	0,0043	0,0117	2,8	13,4
N-V-06 A-V-06	180	590	4.250	0 - 65 0 - 55	14	60	61	140	100 79	90	16 30	47	126	5	0,0081 0,0075	0,0200	4,0 3,9	14,6
N-V-07 A-V-07	200	1.000	3.800	0 - 75 0 - 75	18	70	61	165	112 98	105	18 34	47	136	5	0,0159 0,0187	0,0414	6,0 6,3	16,6
N-V-08 A-V-08	220	1.600	3.450	0 - 85 0 - 75	20	85	72	180	130 110	125	20 37	52	162	5	0,0297 0,0297	0,0639	9,1 8,9	21,8
N-V-09 A-V-09	274	2.400	2.800	40 - 90 0 - 90	20	95	82	210	140 130	135	23 41	62	183	6	0,0544 0,0623	0,1480	12,7 13,5	26,3
N-V-10 A-V-10	314	3.600	2.450	40 - 105 40 - 105	20	105	92	240	160 153	155	27 45	72	203	6	0,1061 0,1158	0,2720	18,7 20,0	32,4
N-V-11 A-V-11	344	5.000	2.200	40 - 120 40 - 120	20	115	98	260	170 168	165	29 49	78	220	7	0,1579 0,1795	0,3950	23,0 25,5	36,6
N-V-12 A-V-12	380	7.200	2.000	40 - 140 50 - 140	22	130	110	300	200 198	195	34 53	88	248	8	0,3341 0,3777	0,6730	35,3 39,0	47,0
A-V-13	430	9.500	1.750	0 - 150	25	140	123	325	218	215	57	98	271	8	0,5599	1,0750	51,0	56,8
A-V-14	480	14.500	1.600	0 - 160	25	170	133	360	228	225	61	108	313	10	0,8952	1,8610	69,0	87,4
A-V-15	575	21.600	1.300	0 - 190	30	190	153	420	278	275	65	123	353	10	1,9300	4,0240	112,0	138,0
A-V-16	615	0.300	1.250	0 - 225	30	210	173	515	338	335	80	143	393	10	5,1340	7,8550	188,5	206,6

Größe Size	N-V 05 A-V	N-V 06 A-V	N-V 07 A-V	N-V 08 A-V	N-V 09 A-V	N-V 10 A-V	N-V 11 A-V	N-V 12 A-V	N-V 13 A-V	N-V 14 A-V	N-V 15 A-V	N-V 16 A-V
D <sub>L</sub> [mm]	9 / M8	11 / M10	11 / M10	11 / M10	14 / M12	18 / M16	18 / M16	18 / M16	22 / M20	22 / M20	26 / M26	26 / M24
T <sub>k</sub> [mm]	142	160	180	200	250	282	312	348	390	440	528	568
Z	6	6	7	8	8	8	8	9	9	10	10	10

Werkstoff der elastischen Elemente - Polyurethan (PUR) / Shorehärte 92 °Shore A

Material Elastic Elements - Polyurethane (PUR) / Shorehardness - 92 °Shore A

Bauform RSZ-V

Type RSZ-V

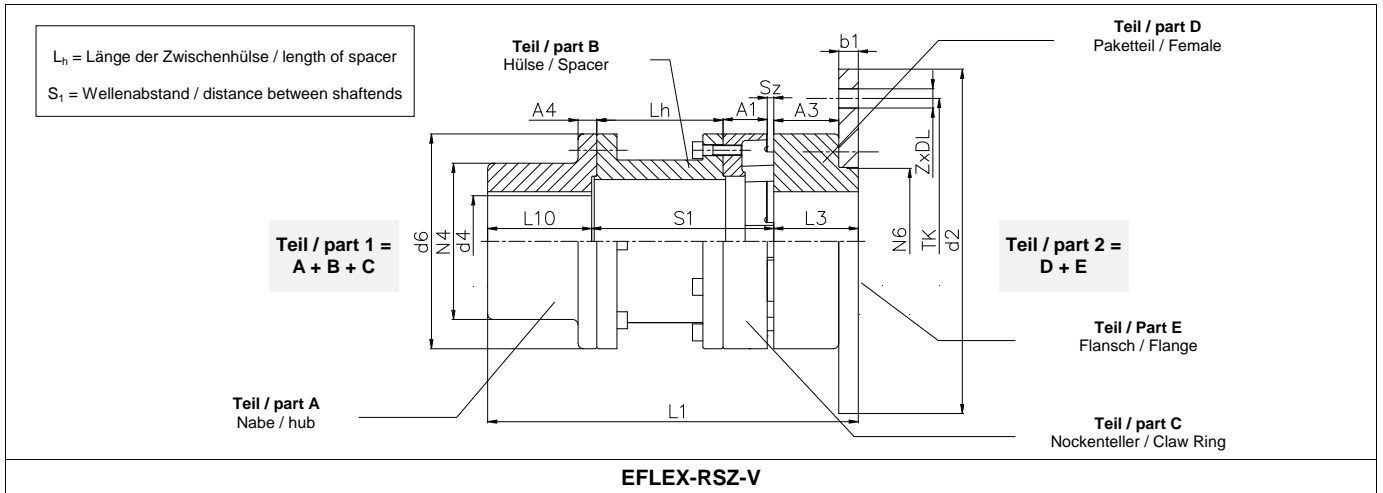

EFLEX-RSZ-V

Größe Size	Nennmoment $T_{kN}$	max. Drehzahl $n_{max}$	min/max Bohrung $d_4$	Flansch $d_2$ (h8)															Massenträgheitsmoment - J		Masse	
	nominal torque [Nm]	max. speed [min <sup>-1</sup> ]	min/max bore	flange	$d_6$	$N_4$	$N_6$	$L_{10}$	$L_3$	$b_1$	$S_1$	$A_3$	$A_4$	$L_h$	$A_1$	$L_1$	$S_z$	Teil 1 part 1	Teil 2 part 2	Teil 1 part 1	Teil 2 part 2	
					[mm]														mass moment of inertia - J [kg.m <sup>2</sup> ]		mass [kg]	
Z-V-05	390	4.850	0 - 60	158	125	90	80	65	57	14	100 140 180	43	11,5	66 106 146	26 262 302	222 262 302	5	0,0136 0,0147 0,0158	0,0114	7,2 8,0 8,8	4,0	
Z-V-06	590	4.250	0 - 65	180	140	100	90	70	61	14	100 140 180 200	47	13	61 101 141 161	30 310 311 331	231 271 311 331	5	0,0220 0,0242 0,0263 0,0279	0,0192	9,3 10,4 11,6 12,2	5,2	
Z-V-07	1.000	3.800	0 - 80	200	165	120	105	80	65	18	140 180 200	47	14,5	97 137 157	34 325 345	285 325 345	5	0,0526 0,0570 0,0603	0,0396	15,8 17,4 18,2	8,6	
Z-V-08	1.600	3.450	0 - 90	220	180	135	125	90	72	20	140 180 200 250	52	19	93 133 153 203	37 342 362 412	302 342 362 412	6	0,0742 0,0793 0,0818 0,0881	0,0612	19,2 20,9 21,8 23,9	10,9	
Z-V-09	2.400	2.800	0 - 100	274	210	150	135	100	82	20	180 200 250	62	19	128 148 198	41 382 432	362 382 432	7	0,1510 0,1580 0,1740	0,1440	27,1 28,3 31,5	18,2	
Z-V-10	3.600	2.450	0 - 120	314	240	180	155	110	92	20	180 200 250	72	21	124 144 194	45 402 452	382 402 452	7	0,3040 0,3140 0,3370	0,2650	40,1 41,5 45,1	25,9	

Größe Size	Z-V-05	Z-V-06	Z-V-07	Z-V-08	Z-V-09	Z-V-10
$D_L$ [mm]	9 / M8	11 / M10	11 / M10	11 / M10	14 / M12	18 / M16
$T_K$ [mm]	142	160	180	200	250	282
$Z$	6	6	7	8	8	8

Werkstoff der elastischen Elemente - Polyurethan (PUR) / Shorehärte 92 °Shore A

Material Elastic Elements - Polyurethane (PUR) / Shorehardness - 92 °Shore A

## Bauform RSN-ERB

## Type RSN-ERB

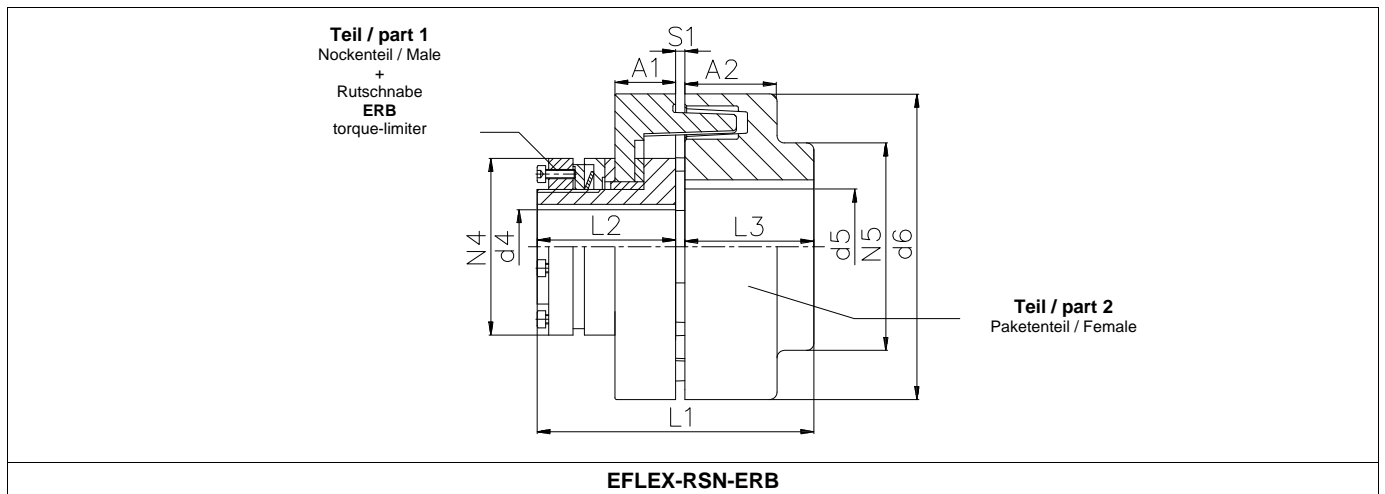

Größe Size	Grensdrehmoment bei Überlast		Grensdrehmoment bei Überlast		max Drehzahl	min/max Bohrung		min/max Bohrung		Masse mass
	$T_{kmax} (1-F) ^{(1)}$		$T_{kmax} (2-F) ^{(2)}$		$n_{max}$	$d_4$		$d_5$		
	max torque for overload		max torque for overload		max speed	min/max bore		min/max bore		
	[Nm]				[min <sup>-1</sup> ]	[mm]				
N-ERB-0	2	10	4	20	8.000	6	10	0	38	1,7
N-ERB-01	6	30	12	60	6.600	10	22	0	42	2,5
N-ERB-1	14	70	28	130	5.600	10	25	0	45	4,1
N-ERB-2	26	130	52	250	4.300	14	35	0	55	6,3
N-ERB-3	50	250	100	550	3.300	18	45	0	75	11,9
N-ERB-4	110	550	220	1.100	2.700	24	55	40	90	26,1
N-ERB-5	140	700	280	1.400	2.200	28	65	40	105	41,2
N-ERB-6	240	1.200	480	2.400	1.900	38	80	40	120	51,4
N-ERB-7	400	2.000	800	4.000	1.600	45	100	0	150	97,2
N-ERB-8	680	3.400	1.360	6.800	1.300	58	120	0	190	201,0

Größe Size	$d_6$	$A_2$	$L_2$	$L_3$	$L_1$	$N_5$	$A_1$	$S_1$
	[mm]							
N-ERB-0	80	30	33	30	66	80	14,3	3
N-ERB-01	94	35	45	35	83	94	24,0	3
N-ERB-1	110	42	52	42	98	110	24,0	4
N-ERB-2	125	45	57	55	116	85	26,0	4
N-ERB-3	165	50	68	70	143	112	31,5	5
N-ERB-4	210	65	78	95	179	140	38,3	6
N-ERB-5	240	75	92	105	203	160	44,3	6
N-ERB-6	260	80	102	115	224	170	49,0	7
N-ERB-7	325	100	113	140	261	220	57,0	8
N-ERB-8	420	125	115	190	315	280	60,0	10

Tellerfeder - 1x	= (1) =	disk spring - 1x
Tellerfeder - 2x	= (2) =	disk spring - 2x

Werkstoff der elastischen Elemente - Polyurethan (PUR) / Shorehärte 92 °Shore A      Material Elastic Elements - Polyurethane (PUR) / Shorehardness - 92 °Shore A

**EFLEX-RS Kupplungen für IEC-Normmotoren<sup>(1)</sup>**

**EFLEX-RS Couplings for IEC Standard Motors<sup>(2)</sup>**

Bei einer Anfahrhäufigkeit von > 25 pro Stunde verliert die Zuordnung ihre Gültigkeit.

In case of a starting frequency > 25 per hour the correlation is no longer valid.

Baugröße Size	d x l <sup>(2)</sup>		P(kW) 50 Hz		P(kW) 50 Hz		P(kW) 50 Hz		P(kW) 50 Hz	
	n = 3.000 min <sup>-1</sup>	n ≤ 1.500 min <sup>-1</sup>	n = 3.000 min <sup>-1</sup>	S <sub>k</sub> =1,3	n = 1.500 min <sup>-1</sup>	S <sub>k</sub> =1,3	n = 1.000 min <sup>-1</sup>	S <sub>k</sub> =1,3	n = 750 min <sup>-1</sup>	S <sub>k</sub> =1,3
			RN/RA		RN/RA		RN/RA		RN/RA	
56	9 x 20		0,09	01/04	0,06	01/04	0,037	01/04		
	9 x 20		0,12	01/04	0,09	01/04	0,045	01/04		
63	11 x 23		0,18	01/04	0,12	01/04	0,06	01/04		
	11 x 23		0,25	01/04	0,18	01/04	0,09	01/04		
71	14 x 30		0,37	01/04	0,25	01/04	0,18	01/04	0,09	01/04
	14 x 30		0,55	01/04	0,37	01/04	0,25	01/04	0,12	01/04
80	19 x 40		0,75	01/04	0,55	01/04	0,37	01/04	0,18	01/04
	19 x 40		1,1	01/04	0,75	01/04	0,55	01/04	0,25	01/04
90S	24 x 50		1,5	01/04	1,1	01/04	0,75	01/04	0,37	01/04
90L	24 x 50		2,2	01/04	1,5	01/04	1,1	01/04	0,55	01/04
100L	28 x 60		3,0	01/04	2,2	01/04	1,5	01/04	0,75	01/04
	28 x 60				3,0	01/04			1,1	01/04
112M	28 x 60		4,0	01/04	4,0	01/04	2,2	01/04	1,5	01/04
132S	38 x 80		5,5	02/04	5,5	02/04	3,0	02/04	2,2	02/04
	38 x 80		7,5	02/04						
132M	38 x 80				7,5	02/04	4,0	02/04	3	02/04
	38 x 80						5,5	03/04		
160M	42 x 110		11,0	03/04	11,0	03/04	7,5	03/04	4	03/04
	42 x 110		15,0	03/04					5,5	03/04
160L	42 x 110		18,5	03/04	15,0	04/04	11,0	04/04	7,5	04/04
180M	48 x 110		22,0	05/05	18,5	05/05				
180L	48 x 110				22,0	05/05	15,0	05/05	11	05/05
200L	55 x 110		30,0	05/06	30,0	05/06	18,5	05/06	15	05/06
	55 x 110		37,0	05/06			22,0	05/06		
225S	55 x 110	60 x 140			37	06/07			18,5	06/07
225M	55 x 110	60 x 140	45	05/06	45	06/07	30	06/07	22	06/07
250M	60 x 140	65 x 140	55	06/07	55	06/07	37	06/07	30	06/07
280S	65 x 140	75 x 140	75	06/07	75	08/08	45	08/08	37	08/08
280M	65 x 140	75 x 140	90	06/07	90	08/08	55	08/08	45	08/08
315S	65 x 140	80 x 170	110	06/07	110	08/09	75	08/09	55	08/09
315M	65 x 140	80 x 170	132	06/07	132	08/09	90	08/09	75	08/09
315L	65 x 140	80 x 170	160	07/07	160	08/09	110	08/09	90	08/09
	65 x 140	80 x 170	200	07/07	200	08/09	132	09/09	110	09/09
355L	75 x 140	95 x 170	250	08/08	250	10/10	160	10/10	132	10/10
	75 x 140	95 x 170	315	08/08	315	10/10	200	10/10	160	10/10
	75 x 140	95 x 170					250	10/10	200	10/10
400L	80 x 170	100 x 210	355	08/09	355	10/10	315	11/11	250	11/11
	80 x 170	100 x 210	400	09/09	400	10/10				
450	80 x 170	110 x 210	500	10/09	500	11/11	400	11/11	315	12/12
	80 x 170	110 x 210	630	10/10	630	12/12	500	12/12	400	12/12

Sicherheitsfaktor = 1,3 (Seite 7)	S <sub>k</sub>	Safety factor = 1,3 (page 7)
Elektromotoren nach DIN 42673 Blatt 1 (1983)	(1)	Three Phase AC Motors according to DIN 42673 part 1 (1983)
Wellenende	(2)	Shaft End
Werkstoff der elastischen Elemente - Polyurethan (PUR)		Material Elastic Elements - Polyurethane (PUR)
Shorehärte 92 °Shore A		Shorehardness - 92 °Shore A

**Nennleistungen (kW) -  
n (Drehzahl - min<sup>-1</sup>)**

Übertragbare Leistung (kW) bei den angegebenen Drehzahlen (min<sup>-1</sup>) -

**Achtung** - bei Verwendung dieser Tabelle soll der Sicherheitsfaktor K vorher berücksichtigt werden.

**nominal power ratings (kW) -  
n (speed - min<sup>-1</sup>)**

Transmittable power (kW) at the following range of speeds (min<sup>-1</sup>) -

**Note** - before using this table the required power rating should be multiplied with the relevant service factor K.

<b>nom. Drehmoment / nom. torque (Nm)</b>															
40	65	110	185	390	590	1.000	1.600	2.400	3.600	5.000	7.200	9.500	14.500	21.600	30.300
<b>max. Drehzahl / max. speed (min<sup>-1</sup>)</b>															
10.000	8.700	7.500	6.300	5.700	5.000	4.400	3.900	3.300	2.900	2.700	2.300	2.100	1.900	1.600	1.350

n	1	2	3	4	5	6	7	8	9	10	11	12	13	14	15	16
[min <sup>-1</sup> ]	[kW]															
10	0,04	0,07	0,12	0,19	0,41	0,62	1,0	1,7	2,5	3,8	5,2	7,5	9,9	15,2	22,6	31,7
12,5	0,05	0,09	0,14	0,24	0,51	0,77	1,3	2,1	3,1	4,7	6,5	9,4	12,4	19,0	28,3	39,7
16	0,07	0,11	0,18	0,31	0,65	1,0	1,7	2,7	4,0	6,0	8,4	12,1	15,9	24,3	36,2	50,8
20	0,08	0,14	0,23	0,39	0,82	1,2	2,1	3,4	5,0	7,5	10,5	15,1	19,9	30,4	45,2	63,5
25	0,10	0,17	0,29	0,48	1,0	1,5	2,6	4,2	6,3	9,4	13,1	18,8	24,9	38,0	56,5	79,3
31,5	0,13	0,21	0,36	0,61	1,3	1,9	3,3	5,3	7,9	11,9	16,5	23,7	31,3	47,8	71,2	99,9
40	0,17	0,27	0,46	0,77	1,6	2,5	4,2	6,7	10,1	15,1	20,9	30,2	39,8	60,7	90,5	127
50	0,21	0,34	0,58	1,0	2,0	3,1	5,2	8,4	12,6	18,8	26,2	37,7	49,7	75,9	113	159
63	0,26	0,43	0,73	1,2	2,6	3,9	6,6	10,6	15,8	23,7	33,0	47,5	62,7	95,7	142	200
80	0,34	0,54	0,92	1,5	3,3	4,9	8,4	13,4	20,1	30,2	41,9	60,3	79,6	121	181	254
100	0,42	0,68	1,2	1,9	4,1	6,2	10,5	16,8	25,1	37,7	52,4	75,4	99,5	152	226	317
125	0,52	0,85	1,4	2,4	5,1	7,7	13,1	20,9	31,4	47,1	65,4	94,2	124	190	283	397
160	0,67	1,1	1,8	3,1	6,5	9,9	16,8	26,8	40,2	60,3	83,8	121	159	243	362	508
200	0,84	1,4	2,3	3,9	8,2	12,4	20,9	33,5	50,3	75,4	105	151	199	304	452	635
224	0,94	1,5	2,6	4,3	9,1	13,8	23,5	37,5	56,3	84,4	117	169	223	340	507	711
280	1,2	1,9	3,2	5,4	11,4	17,3	29,3	46,9	70,4	106	147	211	279	425	633	888
315	1,3	2,1	3,6	6,1	12,9	19,5	33,0	52,8	79,2	119	165	237	313	478	712	999
400	1,7	2,7	4,6	7,7	16,3	24,7	41,9	67,0	101	151	209	302	398	607	905	1.269
500	2,1	3,4	5,8	9,7	20,4	30,9	52,4	83,8	126	188	262	377	497	759	1.131	1.586
630	2,6	4,3	7,3	12,2	25,7	38,9	66,0	106	158	237	330	475	627	957	1.425	1.999
730	3,1	5,0	8,4	14,1	29,8	45,1	76,4	122	183	275	382	550	726	1.108	1.651	2.316
750	3,1	5,1	8,6	14,5	30,6	46,3	78,5	126	188	283	393	565	746	1.139	1.696	2.380
800	3,4	5,4	9,2	15,5	32,7	49,4	83,8	134	201	302	419	603	796	1.215	1.809	2.538
950	4,0	6,5	10,9	18,4	38,8	58,7	99,5	159	239	358	497	716	945	1.442	2.149	3.014
980	4,1	6,7	11,3	19,0	40,0	60,5	103	164	246	369	513	739	975	1.488	2.217	3.109
1.000	4,2	6,8	11,5	19,4	40,8	61,8	105	168	251	377	524	754	995	1.518	2.262	3.173
1.120	4,7	7,6	12,9	21,7	45,7	69,2	117	188	281	422	586	844	1.114	1.701	2.533	3.554
1.250	5,2	8,5	14,4	24,2	51,0	77,2	131	209	314	471	654	942	1.243	1.898	2.827	3.966
1.430	6,0	9,7	16,5	27,7	58,4	88,3	150	240	359	539	749	1.078	1.423	2.171	3.234	
1.600	6,7	10,9	18,4	31,0	65,3	98,8	168	268	402	603	838	1.206	1.592	2.429	3.619	
1.750	7,3	11,9	20,2	33,9	71,5	108	183	293	440	660	916	1.319	1.741	2.657		
2.000	8,4	13,6	23,0	38,7	81,7	124	209	335	503	754	1.047	1.508	1.990			
2.500	10,5	17,0	28,8	48,4	102	154	262	419	628	942	1.309					
2.940	12,3	20,0	33,9	57,0	120	182	308	493	739	1.108						
3.150	13,2	21,4	36,3	61,0	129	195	330	528	792							
3.500	14,7	23,8	40,3	67,8	143	216	366	586								
4.000	16,8	27,2	46,1	77,5	163	247	419									
5.000	20,9	34,0	57,6	96,9	204	309										

Werkstoff Elastische Elemente - Polyurethan (PUR) / Shorehärte 92 °Shore A Material Elastic Elements - Polyurethane (PUR) / Shorehardness - 92 °Shore A

## Fragebogen zur Auslegung

### ANTRIEBSMASCHINE

## Questionnaire for Selection

### DRIVE-R MACHINE

Hersteller / Type Manufacturer / Typ				
Nennleistung	$P_{AN}$		kW	nominal input
Nennrehzahl	$n$		$\text{min}^{-1}$	nominal speed
variabele Drehzahl (... - ...)	$n$	-	$\text{min}^{-1}$	variable speed range (... - ...)
Nenn Drehmoment	$T_{AN}$		Nm	nominal torque
max Anlauf Drehmoment	$T_{AS}$		Nm	max starting torque
Massenträgheitsmoment	$J_m$		$\text{kg.m}^2$	mass moment of inertia
max Drehmoment	$T_{max}$		Nm	max torque
Zahl der stündlichen Anläufe	$Z$		pro Std / per hr	number of starts/stops per hour
Belastung in 2 Drehrichtungen (ja / nein)				bidirectional load (yes / no)
<b>Wellen Ø / shaft Ø (mm)</b>	<b>Wellenlänge / shaftlength (mm)</b>		<b>Nut / keyway (DIN 6885/1)</b>	

### ABTRIEBSMASCHINE

### DRIVE-N MACHINE

Art System	Kreisel Pumpe / Kolben Pumpe / usw. centrifugal pump / reciprocating pump / others			
Hersteller / Type Manufacturer / Typ				
Nennleistung	$P_{LN}$		kW	nominal output
Massenträgheitsmoment	$J_L$		$\text{kg.m}^2$	mass moment of inertia
Nennrehzahl	$n$		$\text{min}^{-1}$	nominal speed
<b>Wellen Ø / shaft Ø (mm)</b>	<b>Wellenlänge / shaftlength (mm)</b>		<b>Nut / keyway (DIN 6885/1)</b>	

### KUPPLUNG

### COUPLING

max axialer Wellenversatz	$\Delta K_a$		mm	max axial shaft displacement
max radialer Wellenversatz	$\Delta K_r$		mm	max radial shaft displacement
max winkliger Wellenversatz	$\Delta K_w$		°	max angular shaft displacement
Umgebungstemperature (min - max)	$T_{min} - T_{max}$	-	°C	ambient temperature (min - max)
Belastung (leicht / mittel / schwer)				shock load (small / moderate / heavy)
max Einbaulänge	$L_{max}$		mm	max build-in length
max Einbau Ø	$d_{6max}$		mm	max build-in Ø
Bremsscheibe / Bremsstrommel (ja / nein)	$d_2 \times (b_1 / b_3)$		mm x mm	brake disc / brake drum (yes / no)
Zwischenhülse (ja / nein) / DBSE	$S_1$		mm	spacer (yes / no) / DBSE
Spielfrei (ja / nein)				zero backlash (yes / no)
Drehsteif / Elastisch / Dämpfung				torsional stiff / elastic / damping
Radial ausbaubare Elemente (ja / nein)				radial mounting of elastic elements (yes / no)
Typengenehmigung ( ja / nein)				type approval (yes / no)
Wuchten (ja / nein)				balancing (yes / no)
Material (GJL250 / GJS400 / Stahl / anders)				material (GJL250 / GJS400 / Steel / others)

### MONTAGEANLEITUNG

### A

### INSTALLATION INSTRUCTIONS

#### Allgemeine Montagehinweise

#### A.1

#### General Notes

Beachten Sie, daß während Montage oder Wartungsarbeiten die Anlage nicht unbeabsichtigt eingeschaltet werden kann. Nach dem Maschinenschutzgesetz muß der Käufer alle umlaufenden Maschinenteile gegen unbeabsichtigtes Berühren schützen.

Prior to performing any installation or maintenance work (including inspections) it is essential that the power supply is isolated and that no movement is allowed of any rotating machinery. In order to comply with the laws regarding guarding of rotating parts, the buyer must ensure that adequate protection is provided over the coupling and other rotating parts.

#### Teileliste EFLEX-RSN

#### A.2

#### Part List EFLEX-RSN

Pos	Teil	Anzahl	Bild 1. Einbauzeichnung EFLEX-RSN	Pos	part	number
1	Welle I	1		 <p>Figure 1. Assembly EFLEX-RSN</p>	1	shaft I
2	Stellschraube	1	2		setscrew	1
3	Nockenteil	1	3		male part	1
4	Element	Tabelle 4.	4		element	Table 4.
5	Stellschraube	1	5		setscrew	1
6	Paketteil	1	6		female part	1
7	Welle II	1	7		shaft II	1

Tabelle 1. Teileliste

Table 1. Part List

1. Elemente [4] in Paketteil [6] laut Bild 3. montieren
2. Nockenteil [3] und Paketteil [6] im Fall einer Übergangspassung oder Preßsitzverbindung erwärmen (\*)
3. Nockenteil [3] auf Welle I [1] und Paketteil [6] auf Welle II [7] ziehen
4. Stellschraube [2] in Nockenteil [3] anziehen
5. Abstand S1 laut Tabelle 6. und Bild 4. kontrollieren
6. Stellschraube [5] in Paketteil [6] anziehen
7. Ausrichtfehler überprüfen anhand Tabelle 6.

1. Mount the elements [4] into the female part [6] acc. figure 3.
2. Heat (\*) male part [3] and the female part [6] in case of slide or tight fitting
3. Mount the male part [3] on shaft [1] and the female part [6] on shaft II [7]
4. Tighten setscrew [2] into male part [3]
5. Check distance S1 acc. table 6. and figure 4.
6. Tighten setscrew [5] into female part [6]
7. Check the misalignment according table 6.

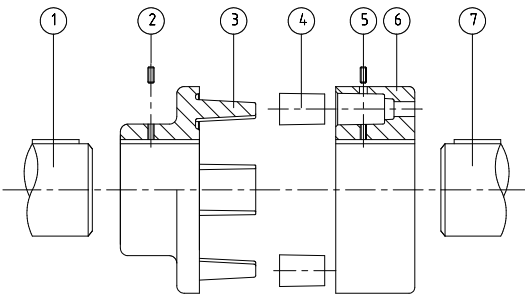
#### Teileliste EFLEX-RSA

#### A.3

#### Part List EFLEX-RSA

Pos	Teil	Anzahl	Bild 2. Einbauzeichnung EFLEX-RSA	Pos	part	number
1	Welle I	1		 <p>Figure 2. Assembly EFLEX-RSA</p>	1	shaft I
2	Schraube	Tabelle 3.	2		bolt	Table 3.
3	Nockenring	1	3		clawring	1
4	Stellschraube	1	4		setscrew	1
5	Nabe	1	5		hub	1
6	Element	Tabelle 4.	6		element	Table 4.
7	Stellschraube	1	7		setscrew	1
8	Paketteil	1	8		female part	1
9	Welle II	1	9		shaft II	1

Tabelle 2. Teileliste

Table 2. Part List

1. Elemente [6] in Paketteil [8] laut Bild 3. montieren
2. Nabe [5] und Paketteil [8] im Fall einer Übergangspassung oder Preßsitzverbindung erwärmen (\*)
3. Nockenring [3] auf Nabe [5] montieren mit Schrauben [2]
4. Schrauben [2] anziehen laut Tabelle 3.
5. Nockenring [3] mit Nabe [5] auf Welle-I [1] und Paketteil [8] auf Welle-II [9] ziehen
6. Stellschraube [4] in Nabe [5] anziehen
7. Abstand S1 anhand Tabelle 6. und Bild 4. kontrollieren
8. Stellschraube [7] in Paketteil [8] anziehen
9. Ausrichtfehler überprüfen anhand Tabelle 6.

1. Mount the element [6] into the female part [8] acc. figure 3.
2. Heat up(\*) hub [5] and the female part [8] in case of slide or tight fitting
3. Mount the clawring [3] on hub [5] with screws [2]
4. Tighten screws [2] acc. table 3.
5. Mount clawring [3] with hub [5] on shaft-I [1] and female part [8] on shaft-II [9]
6. Tighten setscrew [4] into hub [5]
7. Adjust the distance S1 according table 6. and figure 4.
8. Tighten setscrew [7] into female part [8]
9. Check misalignment according table 6.

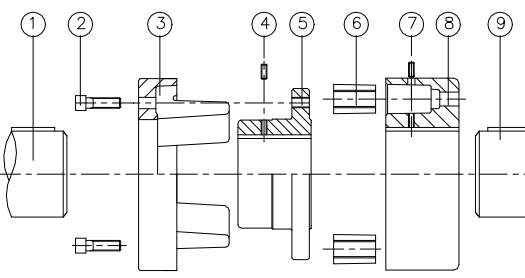
(\*) - Bei Übergangs- und Preßsitzverbindungen dürfen Nockenteil, Nabe, Nockenring und Paketteil (ohne Elemente), kurzzeitig bis 150 °C aufgewärmt werden. Das Paketteil mit Elementen darf kurzzeitig bis 80 °C aufgewärmt werden.

(\*) - For easy assembly in case of transition or tight fitting, clawring, shaft and female part (without elements) can be heated up to maximum 150 °C. The Female part, including elements, can be heated up to 80 °C for a short period of time.

**Umgebung**

**A.4**

**Environment**

Bei Anwendung braunfarbiger Elemente (92° Shore [A]) soll die Betriebstemperatur zwischen - 30°C und + 80° C liegen. Bei Anwendung naturfarbiger Elemente (80° Shore [A]) soll die Betriebstemperatur zwischen - 60°C und + 70°C liegen. Bei Dieselmotoranwendungen sind nur naturfarbige Elemente geeignet, da diese Elemente Drehschwingungen, erregt durch z.B. einen Dieselmotor, dämpfen.

When using light brown elements (92° Shore [A]), the operating temperatures must be between - 30°C en + 80° C. When using natural coloured elements (80° Shore [A]), the operating temperatures must be between - 60°C and + 70°C . For diesel engine driven applications only the natural coloured elements are suitable. These elements are suitable to dampen torsional vibrations caused by for instance a diesel engine.

**Anziehmomenten der Nockenringschrauben**

**A.5**

**Tightning torques of the clawing-bolts**

Größe Size	Schraube DIN 933 - G10.9 screw	Anzahl Quantity	Anziehmoment [Nm] tightening torque	Größe Size	Schraube DIN 933 - G10.9 screw	Anzahl Quantity	Anziehmoment [Nm] tightening torque
RSA-04	M6 x 20	4	14	RSA-11	M12 x 45	6	117
RSA-05	M8 x 25	4	34	RSA-12	M16 x 50	6	280
RSA-06	M8 x 30	4	34	RSA-13	M16 x 55	6	280
RSA-07	M8 x 30	6	34	RSA-14	M20 x 60	6	560
RSA-08	M10 x 35	6	68	RSA-15	M24 x 65	6	960
RSA-09	M10 x 40	6	68	RSA-16	M24 x 80	6	960
RSA-10	M12 x 40	6	117				

Tabelle 3. Anziehmoment

Table 3. Tightning Torque

**Anzahl Elemente**

**A.6**

**Number of Elements**

Größe Size	Anzahl Elemente number of elements		Größe Size	Anzahl Elemente number of elements
1	6		9	12
2	8	10	12	
3	8	11	12	
4	8	12	12	
5	8	13	12	
6	8	14	12	
7	12	15	12	
8	12	16	12	

Tabelle 4. Elemente

Table 4. Elements

**AUSRICHTHINWEISE**

**B**

**ALIGNMENT INSTRUCTIONS**

**Abstand**

**B.1**

**Distance**

Bei allen Bauformen muß der Abstand 'S1' (Bild 4.) eingehalten und gemessen und möglichst genau auf die in Tabelle 6. angegebenen Werte eingestellt werden (Meßuhr, Lineal, Schiebellehre, Tiefenmaß).

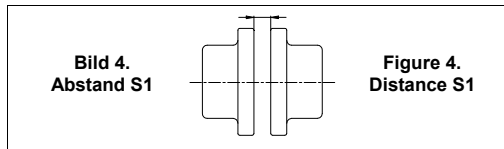

For all designs the distance between both hubs should be kept at 'S1' (Figure 4.) and has to be measured. It has to be adjusted - as exact as possible - to the value 'S1' as shown in table 6. (ruler, slide gauge, depth gauge, clock gauge).

**Ausrichten**

**B.2**

**Misalignment**

Nach der Montage sollen die radialen, axialen und winkligen Wellenversätze gemessen werden, mit Lasermeßgerät oder Meßuhr, Lineal, Meßschieber und Endmaßen. Die in Tabelle 6. angegebenen Werte für Ausrichttoleranzen sind als Richtwerte anzusehen, da das tatsächliche Ausgleichsvermögen der Kupplung sehr stark von der Drehzahl und der Belastung abhängt. Eine genaue Ausrichtung der Kupplungshälften erhöht die Lebensdauer der elastischen Kupplungs-elemente und Lager in der Anlage.

After installation the axial, radial and angular misalignment should be measured with laser or dial gauge, dial blocks and straightedge. It should be noted that the values in Table 6. should not be exceeded as the actual capability of the coupling to accommodate for misalignment is a function of the speed and the application. The greater the degree of accuracy of initial alignment the greater the length of trouble free life of the elastic elements and the bearings of the driver and driven machinery.

Die aufgeführten Verlagerungswerte gelten bei Nenndrehmomente, stoßfreiem Betrieb, Drehzahl = 1.500 min<sup>-1</sup> und Umgebungstemperatur - 30°C bis + 80°C. Zulässiger Versatz ist ΔK<sub>r,zul</sub>·S<sub>n</sub> bzw. ΔK<sub>w,zul</sub>·S<sub>n</sub> (S<sub>n</sub> - Tabelle 5.). ΔK<sub>r</sub> und ΔK<sub>w</sub> können gleichzeitig auftreten. Die %-Summe der beiden vorhandenen Versätze ΔK<sub>r,vorh</sub> und ΔK<sub>w,vorh</sub> ist maximal 100%.

The listed displacement values apply at nominal torque, under shock-free operating conditions, nominal speed = 1.500 min<sup>-1</sup> and ambient temperatures - 30°C to + 80°C. Permissible displacement is ΔK<sub>r,zul</sub>·S<sub>n</sub> or ΔK<sub>w,zul</sub>·S<sub>n</sub> (S<sub>n</sub> - Table 5.). ΔK<sub>r</sub> and ΔK<sub>w</sub> could occur simultaneously. The %-sum of the two measured displacements ΔK<sub>r,vorh</sub> and ΔK<sub>w,vorh</sub> should not exceed 100%.

$\frac{\Delta K_{r,vorh}}{\Delta K_{r,zul} \times S_n} \times 100\% + \frac{\Delta K_{w,vorh}}{\Delta K_{w,zul} \times S_n} \times 100\% \leq 100\%$	$\Delta K_{r,zul} / \Delta K_{w,zul} = \text{zulässige Versätze (Tabelle 6.) / permissible displacements (table 6.)}$ $\Delta K_{r,vorh} / \Delta K_{w,vorh} = \text{vorhandene Versätze / measured displacements}$
--	---

Drehzahl/Speed (min <sup>-1</sup> )	S <sub>n</sub>	axial / axial - ΔK <sub>a</sub>	radial / radial - ΔK <sub>r</sub>	winklig / angular - ΔK <sub>w</sub>
500	1,0			
1.000	1,0			
1.500	1,0			
2.000	0,8			
2.500	0,6			
3.000	0,4			

Tabelle /Table 5.

Bild 5. Ausrichten

Figure 5. Alignment

Größe Size	Abstand S1 distance	axial $\Delta K_a$ axial	radial $\Delta K_r$ radial	winklig $\Delta K_w$ angular	winklig $\Delta K_w$ angular	Größe Size	Abstand S1 distance	axial $\Delta K_a$ axial	radial $\Delta K_r$ radial	winklig $\Delta K_w$ angular	winklig $\Delta K_w$ angular
	[mm]				[°]		[mm]				[°]
RS-01	3	± 0,75	0,24	± 0,05	0,10	RS-09	6	± 1,50	0,76	± 0,17	0,10
RS-02	3	± 0,75	0,26	± 0,06	0,10	RS-10	6	± 1,50	0,84	± 0,20	0,10
RS-03	3	± 0,75	0,30	± 0,07	0,10	RS-11	7	± 1,75	0,95	± 0,23	0,10
RS-04	4	± 1,00	0,36	± 0,08	0,10	RS-12	8	± 2,00	1,00	± 0,25	0,10
RS-05	4	± 1,00	0,42	± 0,09	0,10	RS-13	8	± 2,00	1,15	± 0,28	0,10
RS-06	5	± 1,25	0,50	± 0,11	0,10	RS-14	10	± 2,50	1,30	± 0,31	0,10
RS-07	5	± 1,25	0,60	± 0,13	0,10	RS-15	10	± 2,50	1,40	± 0,36	0,10
RS-08	5	± 1,25	0,70	± 0,15	0,10	RS-16	10	± 2,50	1,50	± 0,41	0,10

Tabelle 6. Position und Wellenversätze

Table 6. Position and Misalignment

## WARTUNG

## C

## MAINTENANCE

### Wartung der Elementen

### C.1

### Maintenance of Elements

Die EFLEX-RS Kupplungen sind wartungsfrei und bedürfen außer der kontinuierlichen Kontrolle der elastischen Elemente keiner besonderen Pflege.

Verschlossene Elemente sollen immer durch original EFLEX-RS Elemente ersetzt werden, damit die Drehsteifigkeit und Dämpfung sich nicht ändert.

Der Ein- und Ausbau verschlossener Elemente bei der RSA-Bauform lässt sich einfach vollziehen (Bild 6.).

1. Die Position des Nockenring [3] auf der Nabe [5] kennzeichnen.
2. Die Schrauben [2] lösen.
3. Den Nockenring [3] nach hinten schieben.
4. Die Elemente [6] austauschen.
5. Den Nockenring [3] und die Nabe [5] wieder in der ursprünglichen Position verschrauben [2] mit den in Tabelle 3. angegebenen Anzugs-momenten um Vibrationen durch Unwucht zu vermeiden.



Bild / Figure 6.

The EFLEX-RS couplings are maintenance free. EFLEX-RS couplings do not require any particular servicing except for continuous checking of the elastic elements.

Worn elements should be replaced by original EFLEX-RS elements, so that stiffness and damping do not change.

In case of the RSA-execution, the elements can easily be replaced (Figure 6.).

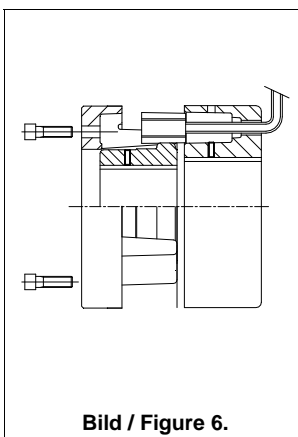
1. Mark first present position clawring [3] on hub [5].
2. Dismount the screws [2].
3. Move clawring [3] back.
4. Replace the elements [6].
5. Mount clawring [3] in original position and tighten the bolts [2] acc. Table 3. Refer to the marking position from the beginning of the operation, to prevent vibration due to unbalance.